

CELTEC

CELTEC® Premium Signboard Solutions



The VYCOM CELTEC® family of graphic and display materials is designed with a unique combination of performance features that make them ideal for digital and screen printing, signage, exhibits, POP, and more. Our materials are lead and heavy metal free, which allows them to safely optimize performance.

CELTEC[®] ULTRA WHITE SOLID PVC

Our advanced CELTEC[®] solid PVC formulation is designed specifically for outdoor applications where resistance to ultraviolet (UV) degradation and impact strength are critical. Performance tests indicate that Ultra White[®] is up to eight times more resistant to UV damage and is both digital and screen printable.

Top Applications:

- Outdoor Signage
- Real Estate Signs
- Exterior Chemical Processing Equipment

Key Material Benefits:

- Printable for Both Digital and Screen
- Superior Outdoor Performance
- High Gloss Finish
- No Pretreatment Required
- Durability

COLORS	① ULTRA WHITE[®]
THICKNESSES	2MM, 3MM, 6MM
FINISH	SMOOTH

Standard sheet size in most thicknesses and formulations is 4' x 8'.
Custom sizes available upon request.

Competitive Advantages

(vs. similar materials):

- UV Performance
- Excellent Impact Properties
- Multiple Sizes Available
- Thermoformable
- Die Cuttable

Compliances:

- UL 94 V-0
- ASTM-E-84
- ASTM-1784-11
- RoHS Compliant
- REACH Compliant

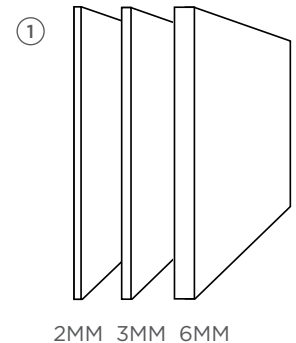

CELTEC[®] TEXTURED EXPANDED PVC

CELTEC[®] Textured Expanded PVC material adds eye-catching dimension to digitally crafted signage by offering print service providers a new level of design flexibility with the same production ease of our CELTEC[®] Expanded PVC. A versatile, durable solution for artistic expression perfect for stand-out signage, exhibits, POP and other applications requiring printed or unprinted textural surfaces.

Top Applications, Key Material Benefits, Competitive Advantages & Compliances are the same as CELTEC[®] Expanded PVC.

COLORS	① WHITE
THICKNESSES	9MM, 12MM, 19MM, 25MM
FINISH	WOODGRAIN (1-SIDED)

Standard sheet size is 4' x 8'.
Custom sizes available upon request.

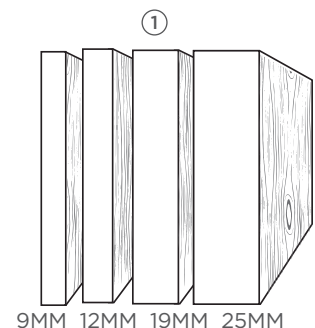

CELTEC[®] EXPANDED PVC

CELTEC[®] Expanded PVC family of graphic and display materials offers the print and design communities a broad range of colors and sizes, providing the flexibility to achieve the desired look. Eye-popping colors make images come to life while product formulation provides consistency in aesthetics and workability for the most demanding applications including signage, exhibits, point of purchase displays and more.

Top Applications:

- Point of Purchase Displays
- Signage
- Store Fixtures
- Exhibits & Kiosks
- Dimensional Letters
- Display Boards
- Monument Signage
- Wayfinding
- Routed Signs

Key Material Benefits:

- Printable for Both Digital & Screen
- Light Weight
- Easy to Fabricate, Paint, or Laminate
- Excellent Fastening Characteristics
- Superior FR Properties

Competitive Advantages

(vs. similar materials):

- Superior UV Performance
- Contains No Heavy Metals
- Die Cuttable
- Optimal Density Superior for Performance
- Short Lead Times for Custom Sizes & Colors
- Oversized Sheets
- All Materials Produced in the U.S.

Compliances:

- UL 94 V-0
- RoHS Compliant
- REACH Compliant
- ASTM-1784-11

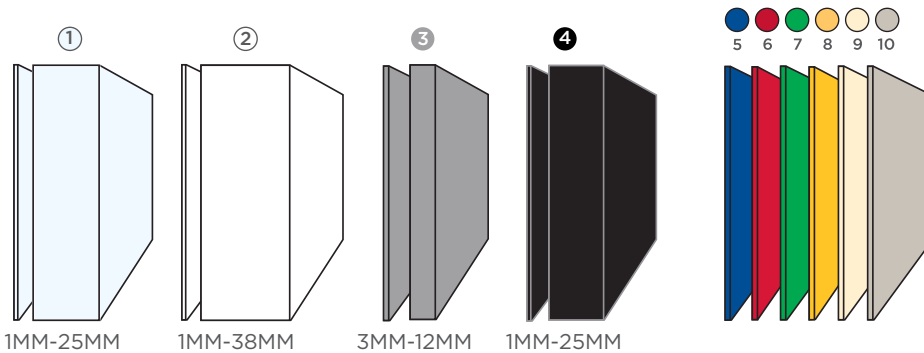

COLORS	① VIVID WHITE [®]	② WHITE	③ GRAY (8C)	④ BLACK
THICKNESSES	1MM - 25MM	1MM - 38MM	3MM - 12MM	1MM - 25MM
FINISH	SATIN SMOOTH	SATIN SMOOTH	SATIN SMOOTH	SATIN SMOOTH

Standard sheet sizes in most thicknesses and formulations are 4' x 8', 4' x 10', 5' x 10', 5' x 8'.
Custom sizes available upon request.

COLORS	⑤ BLUE	⑥ RED	⑦ GREEN	⑧ YELLOW	⑨ BEIGE	⑩ STONE (4C)
THICKNESSES	3MM, 6MM	3MM, 6MM	3MM	3MM, 6MM	3MM	3MM, 6MM
FINISH	SATIN SMOOTH	SATIN SMOOTH	SATIN SMOOTH	SATIN SMOOTH	SATIN SMOOTH	SATIN SMOOTH

Standard sheet size in most thicknesses and formulations is 4' x 8'.
Custom colors and sizes available upon request.

CELTEC® DIGILITE®

CELTEC® DigiLite® delivers economical design flexibility for sign makers and printers, backed by the same premium print quality as our CELTEC® Expanded PVC. This light-density alternative comes through with on-point product formulation and superior UV performance, ensuring consistent aesthetics and durability.

Top Applications:

- Point of Purchase Displays
- Signage
- Store Fixtures
- Exhibits & Kiosks
- Display Boards
- Interior Décor

Key Material Benefits:

- Printable for Both Digital & Screen
- Light Weight
- Easy to Fabricate, Paint, or Laminate
- Superior FR Properties
- 100% Recyclable

Competitive Advantages

(vs. similar materials):

- Superior UV Performance
- Contains No Heavy Metals
- Light Density, Economical Alternative
- Short Lead Times for Custom Sizes & Colors
- Oversized Sheets
- All Materials Produced in the U.S.

Compliances:

- UL 94 V-0
- UL-1975
- RoHS Compliant
- REACH Compliant



COLORS	① WHITE	② BLACK
THICKNESSES	3MM, 6MM	3MM, 6MM
FINISH	SMOOTH	SMOOTH

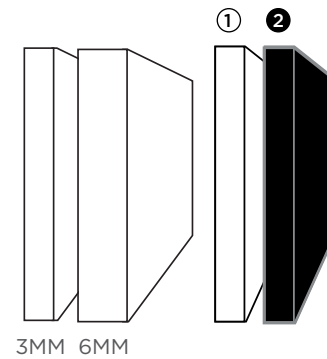

Standard sheet size is 4' x 8'.
Custom sizes available upon request.





VYCOM[®]

OLEFIN & PVC SHEET

These suggestions and data are based on information we believe to be reliable. They are offered in good faith, but without guarantee, as conditions and methods of use are beyond our control. We recommend that the prospective user determines the suitability of our materials and suggestions before adopting them on a commercial scale.

© 2024 PLASKOLITE, LLC 062024
VYCOM[®] and CELTEC[®] are registered trademarks of PLASKOLITE LLC

PLASKOLITE

400 W. Nationwide Blvd, Suite 400
Columbus, OH 43215
800.848.9124 • Fax: 877.538.0754
plaskolist@plaskolite.com
www.plaskolite.com