

PLASKOLITE

OPTIX[®] Plazcryl Guidebook Extruded Acrylic Sheets

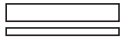

Solid Sheets



Multi Wall Sheets



Corrugated Sheets

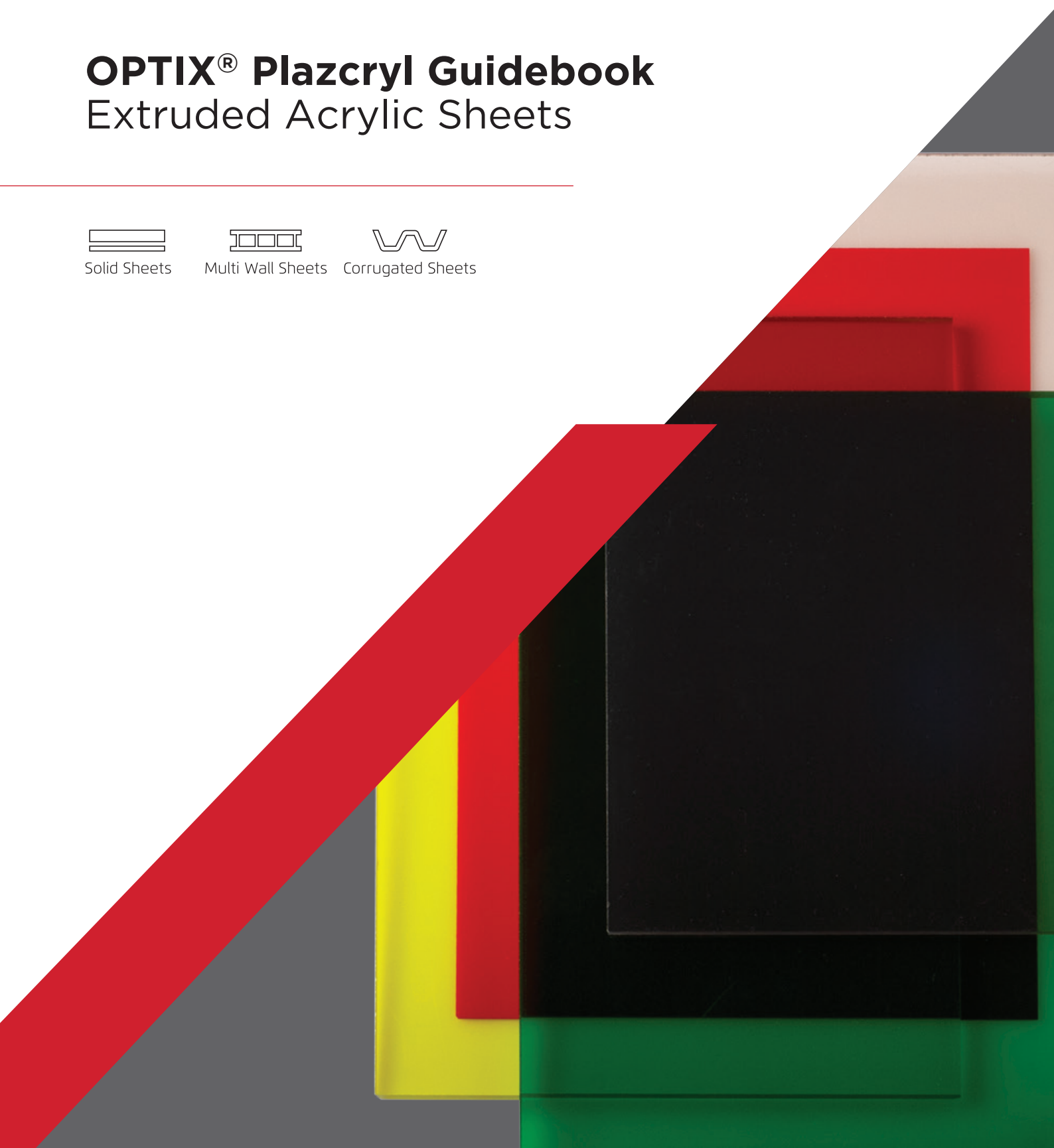



Contents

1.	Introduction	5	6.	Machining Plazcryn Sheets	27
2.	Characteristics Of Plazcryn	7	6.1	Basic Rules for Machining Plazcryn	27
2.1	Qualities	7	6.2	Cutting	27
2.2	Applications	7	6.3	Laser Cutting	31
3.	Handling Plazcryn Sheets	9	6.4	Drilling	32
3.1	Burning Behavior	9	6.5	Routing	34
3.2	Sheets Storage	9	6.6	Engraving	35
3.3	Protective Film	9	6.7	Finishing	36
3.4	Machining And Forming With PE Film	10	6.8	Scraping	36
3.5	Cleaning Plazcryn Sheets	10	6.9	Sanding	36
3.6	Plazcryn Environmental Advantages	10	6.10	Polishing	37
4.	Technical Properties	13	6.11	Cold Bending	39
4.1	Standard Sizes	13	6.12	Thermoforming	40
4.2	Colors	13	6.13	Annealing	49
4.3	Fire Properties	13	6.14	Decorating	50
4.4	Noise Reduction Properties	13	7.	Assembling Plazcryn	55
4.5	Typical Properties - Plazcryn - Extruded Acrylic Sheets	14	7.1	Screwing	55
4.6	Typical Properties - Plazcryn Super - Extruded High Impact Acrylic Sheets	15	7.2	Bonding	56
4.7	Chemical Properties	16	7.3	Sealing	61
4.8	ESC (Environmental Stress Cracking)	17	7.4	Welding	61
4.9	Heat Transmission	17	8.	Glazing and Signage Installation	63
4.10	Solar Transmission	18	8.1	Maximum Wind Load	63
5.	Plazcryn Special Grades	21	8.2	Plazcryn's Thickness	64
5.1	Plazcryn Embossed Sheets	21	8.3	Expansion Clearance	65
5.2	Plazcryn IR-Solar	23	8.4	Glazing Depth	66
5.3	Plazcryn Anti Glare (AG)	24	8.5	Glazing Width	67
5.4	Acryled XT	24			
5.5	Plazcryn Mirror and Top	24			

Introduction



1. Introduction

Plazcryn is the trade name of extruded acrylic (PMMA) sheets made by the PLASKOLITE. PMMA (polymethyl methacrylate) is the most important member of the acrylic polymers. Acrylic was first produced in early 1930s for potential uses in aircraft glazing.

High Impact acrylic grades were introduced in the early 1970s. High impact grades are composed of a hard phase and an acrylic impact modifier soft phase. The amount of soft phase determines the impact increase of the material.

Acrylic is the most beautiful plastic, outstanding for its crystal-like optical qualities and weatherability.

It is the most transparent polymer with a visible light transmittance of 92%, more than glass and any other transparent polymer.

It has a unique inherent resistance to sunlight and environmental exposure for a long period of time. Does not yellow or undergo significant physical changes and keeps its original color and finishes for many years. It has also high scratch resistance and can be manufactured to have a beautiful high gloss finish. Acrylic can be modified by different additives to perform specific applications: impact resistance, UV and IR blocking, etc.

With bright clarity and gloss, excellent transparency and easy fabrication, Plazcryn extruded acrylic sheets provide long-life UV resistant products for a wide range of applications. Plazcryn is available in wide range of thicknesses, colors, textures, special effects and also in wide range of high impact grades (Plazcryn Super).

Plazcryn sheets are produced in clean room environments using computerized state-of-the-art video technology in order to detect any imperfection in the sheets. A skilled team of engineers work 24 hours a day, 7 days a week, to improve materials and production processes and provide technical support to customers and help them to solve any technical challenge.

Plazcryn sheets are produced according to the EN ISO 7823-2 standard.

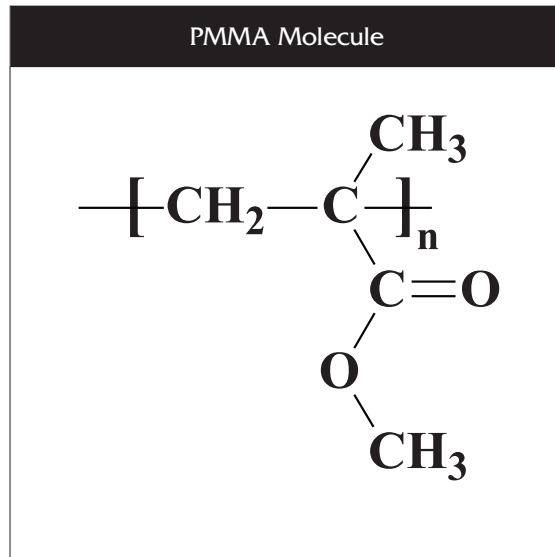

Characteristics

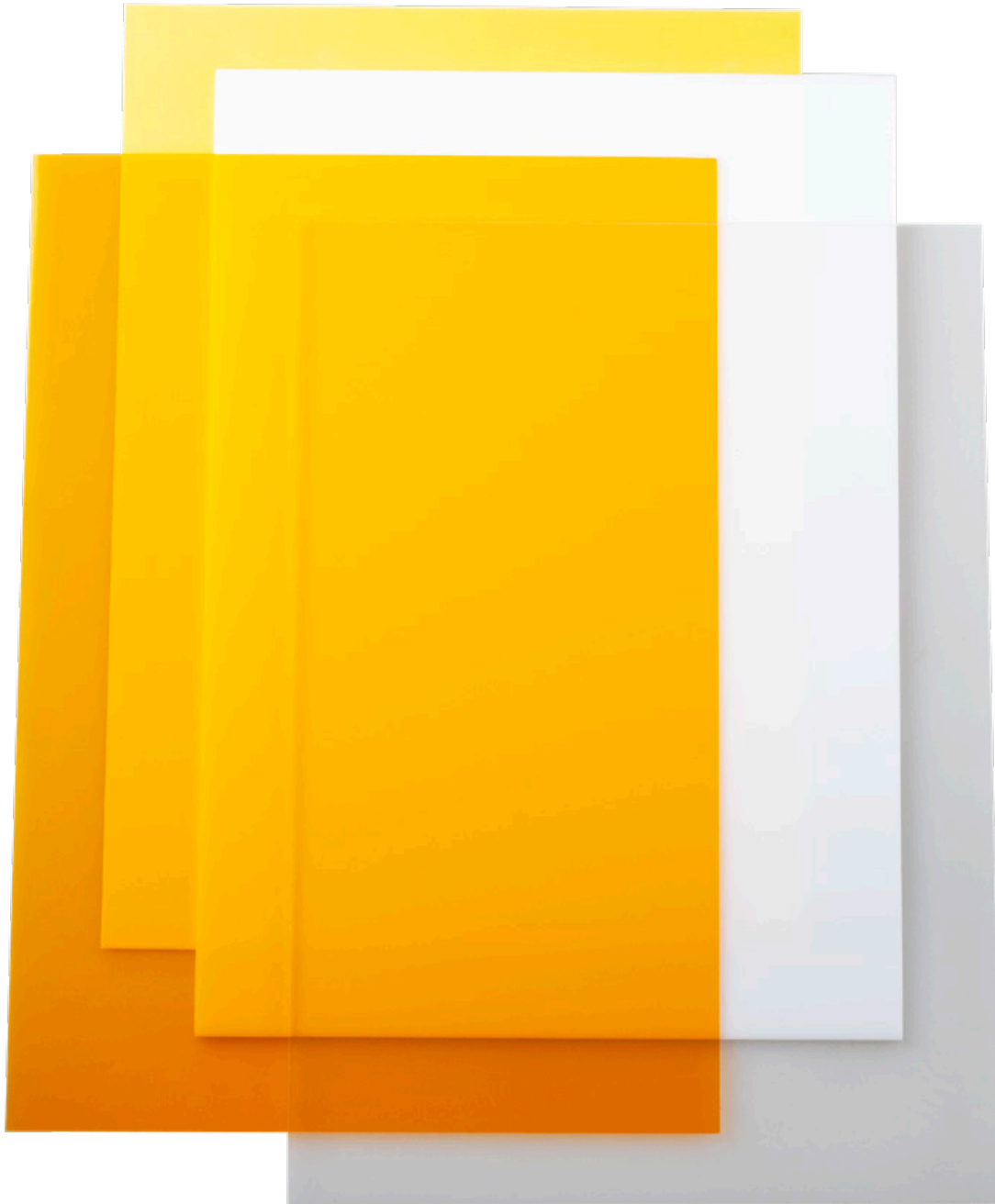

2. Characteristics Of Plazcryn

2.1 Qualities

- Highly transparent, 92% at greatest thickness. Low Haze.
- Beautiful glossy surface.
- Matte surface (anti-glare, anti-reflect) and special embossed patterns available. Excellent color stability. A wide range of translucent and opaque colors available. Lightweight. Less than half weight of glass.
- Intrinsically UV resistant, excellent weathering and ageing resistance. Ten years limited warranty. High hardness, stiffness and strength.
- Excellent dimensional stability.
- High impact grades with excellent impact strength. Special UV and IR blocking sheets available.
- Easily machined and thermoformed by standard techniques. Cold curving capability.
- Easy glue bonded.
- Easily polished and reshaped.
- Good chemical resistance to a wide range of substances. Easy to clean.
- Plazcryn sheets and their polyethylene protective layers are fully recyclable.
- Plazcryn and Plazcryn Super clear and opal sheets can be used in contact with foodstuffs.
- Friendly to the environment. Do not contain any toxic materials or heavy metals, which may cause environmental damage or health risks.
- REACH and RoSH declarations available.
- Do not produce toxic or corrosive gases upon burning. Fire can be easily extinguished with water.

2.2 Applications

Plazcryn extruded acrylic sheets are so versatile and easy to fabricate that they are a number one choice for manufacturers and designers alike.

Plazcryn can be used both indoor and outdoor for a wide variety of domestic and industrial applications:

Building Industry:

- Glazing.
- Shades and terrace roofing.
- Sky domes.
- Architectural uses.
- Greenhouses.

Interior Uses:

- Interior decoration.
- Light fittings.
- Shower cabinets.
- Furniture.

Motor Industry:

- Noise reduction barriers.
- Car number plates.
- Motorcycle shields.
- Caravan roofing.

Advertising Industry:

- Illuminated signs.
- Signboards.
- POP display stands.
- Light diffusers.
- Publication.
- Display cases.

Handling



3. Handling Plazcryn Sheets

Plazcryn is a rigid sheet, which with wrong handling can break, leaving sharp edges. Handling Plazcryn must be done with care, always using protective gloves and shoes.

3.1 Burning Behavior

Plazcryn sheets are combustible, and if not extinguished, will burn to completion once ignited, producing molten droplets, which will continue to burn.

When burning, in the presence of sufficient air, Plazcryn releases CO₂ and water, however if there is a lack of sufficient air toxic CO can be formed.

When storing or working with Plazcryn, the necessary fire precautions must be considered, taking into account the burning behavior of Plazcryn.

3.2 Sheets Storage

Plazcryn sheets must be stored with their original protective masking in a cool, dry and well-ventilated room, at a reasonable constant temperature, away from direct sunlight, excessive humidity, rain or solvent's vapors. Failing to store Plazcryn in adequate conditions can produce distortions in the sheets and other effects, which will make later fabricating, a more difficult task. Long term exposure to the sun or other heat sources can cause fusing of the protective polyethylene (PE) film to the sheet surface impeding its removal. Plazcryn sheets are best stored horizontally on their delivery pallets. Pay attention to avoid pressure on the unsupported areas.

Never leave uncovered sheets or pallets. It is advisable to replace the original packaging over the stack after a sheet is removed from stock to avoid moisture absorption. If stored for long time, the use of dry-packaging is highly recommendable.

3.3 Protective Film

Both surfaces of Plazcryn sheet are protected by a fully recyclable PE film. Keep this film in position as long as possible and remove only and immediately after installation.

Sharp objects, sharp particles or even small chips can penetrate the protective PE masking, and damage the surface, therefore always lay Plazcryn on a clean smooth surface.

There are two kinds of protective film for Plazcryn:

1. Universal film

- This is the standard film used on Plazcryn sheets.
- This film is suitable for machining as well as for thermoforming.

2. Easy removal film

- This film is suitable for sheets that require removal of the PE before processing.
- This film is not suitable, if machining of the sheet is required with the protective film on the sheet.

Both of the above types of film are suitable for thermoforming and laser cutting.

3.4 Machining And Forming With PE Film

It is preferable to leave the protective film in position throughout machining to keep the sheet surface in perfect condition. Normal thermoforming temperatures do not affect the adhesive used for the film on Plazcryn sheets and can therefore be left in place during most heating and forming operations. However, care should be taken to ensure there are no defects in the film (holes, scratches, bubbles), which could mark the part during the forming process. High-heat deep-draw thermoforming applications can cause the PE film to adhere more strongly. Printed film must be removed before thermoforming, to avoid transfer of the printing ink to the sheet's surface.

3.5 Cleaning Plazcryn Sheets

Plazcryn sheets are produced in clean room environment and do not need to be cleaned before use. However, cleaning may be needed after fabrication, before sensitive processes like vacuum metallization or printing or for maintenance during use. In the case that Plazcryn sheets need to be cleaned, wash the sheet surface with clean fresh water with a mild soap. Be sure that the soap you are using is compatible with PMMA. Test a hidden area before cleaning. Use a clean, soft cloth or sponge and rinse well. Do not scrub or use brushes. Dry with a soft cloth. Do not rub dry. The use of window cleaning fluids or solvents such as alcohols, turpentine, acetone, etc., can cause damage to the sheet.

3.6 Plazcryn Environmental Advantages

Plazcryn sheets are environmental friendly. LCA (Life Cycle Assessment) is a methodology used to assess the environmental impact of a product. The LCA evaluates quantitative information about resources consumption and waste production during the whole life cycle of a product (cradle to grave). LCA and Ecoprofiles of PMMA sheet production show a low impact on the environment.

(see: <http://www.plasticseurope.org/plasticssustainability/eco-profiles> for an Ecoprofile of PMMA extruded sheets, including Plazcryn). The outstanding chemical stability and long-time resistance to aging and weathering of Plazcryn sheets often ensures a service time of decades. They do not need to be removed or replaced for many years reducing the environmental burden of plastics waste. The sheets and their polyethylene protective layers are fully recyclable. They do not contain any toxic materials, halogens or heavy metals which may cause environmental damage or health risks. Plazcryn sheets do not contain Bisphenol-A. Ozone Depleting Substances (ODP) are not used in the manufacture of Plazcryn sheets. Plazcryn do not release pollutant substances to the environment during manufacture. They do not produce toxic or corrosive gases upon burning. Fires can be extinguished with water.

Plazcryn sheets can be used for energy recovery and chemical or mechanical recycling. Plazcryn scrap is not classified as hazardous waste. Small amounts can be disposed as household refuse. Large quantities should be disposed for recycling.

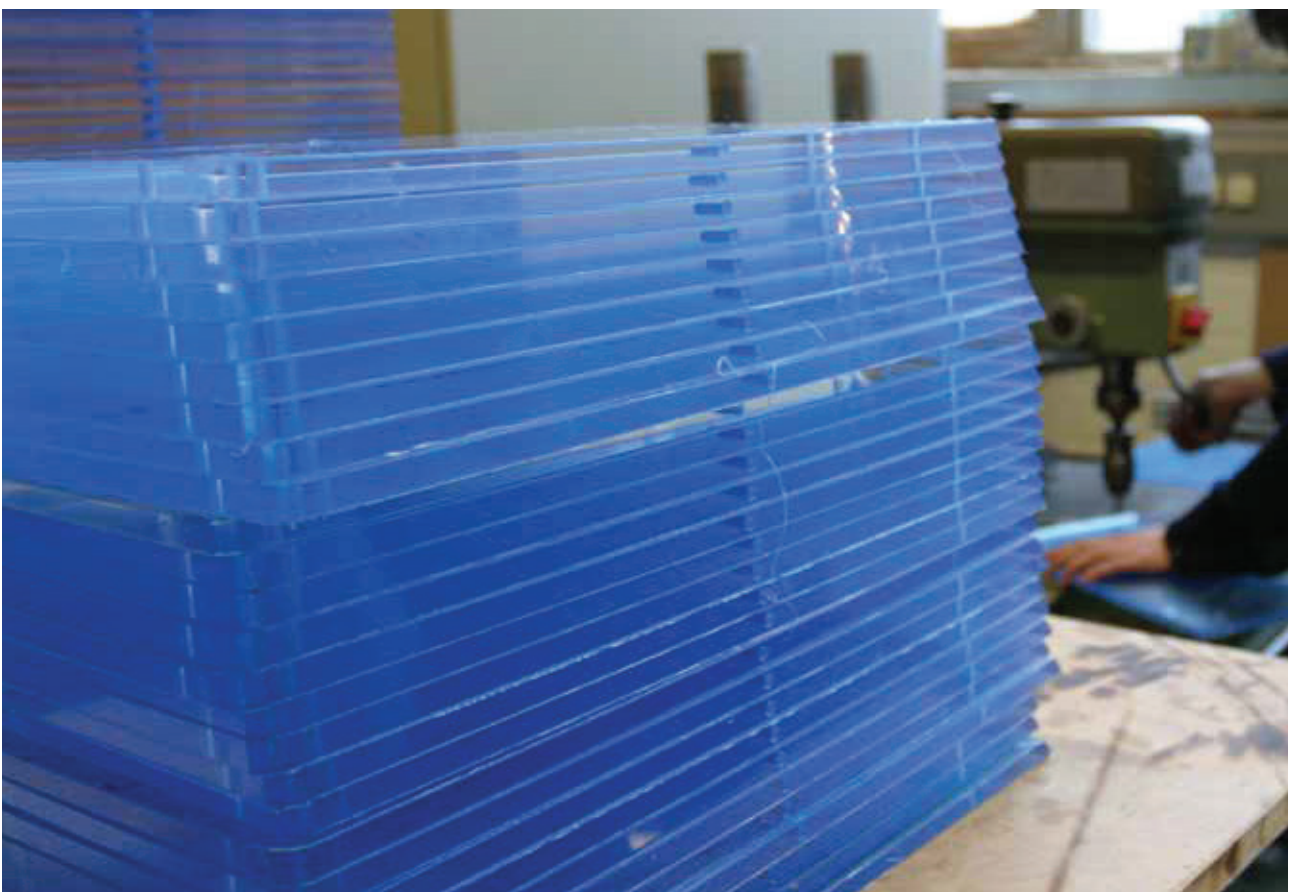
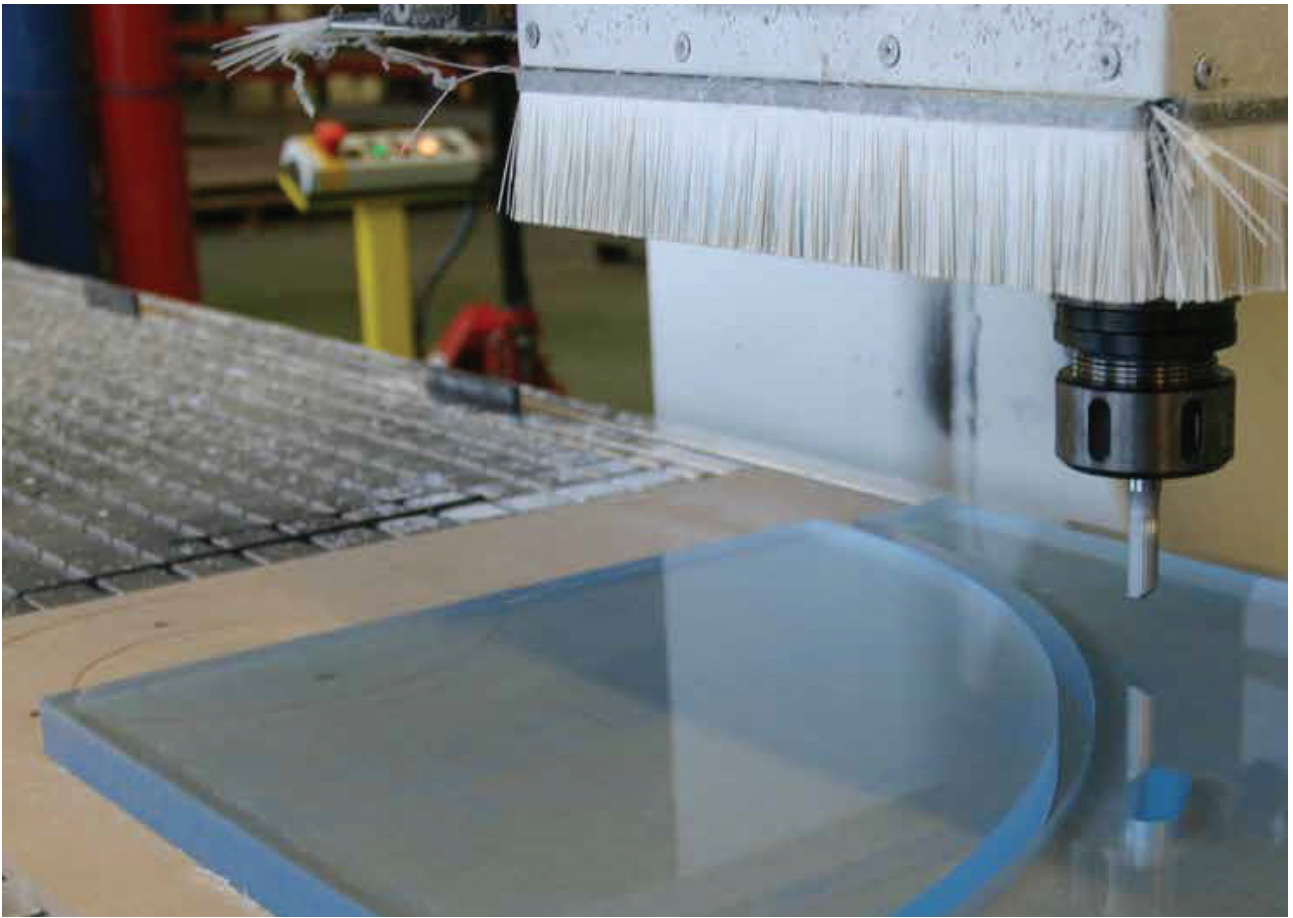

Technical Properties



4. Technical Properties

Please note that technical values given in this guidebook are typical values for your guidance. They are not to be taken as specifications and are subject to certain variability.

4.1 Standard Sizes

- **Thickness** 0.70 – 30.0 mm
- **Width** 1000, 1220 and 2050 mm
- **Length** 600 – 6000 mm

Sheets are also available cut to size, according to customer requirements.

4.2 Colors

Plazcryn sheets are naturally colorless and exceptionally clear, however they can be pigmented to obtain a wide range of tints and colors. They are available transparent and in a wide range of translucent colors, opaque colors, opals and diffusers. Plazcryn colored sheets maintain the same light transmission percentages regardless of thickness (except for opal). For a list of updated colors please contact your regional supplier.

4.3 Fire Properties

PMMA is a combustible material and will burn if ignited. However, unlike other polymers, does not produce toxic or corrosive gases and produces very little smoke, an important safety benefit.

Plazcryn extruded Acrylic sheets classify:

- HB according to UL94.
- E according to UNE-EN ISO 13501.

4.4 Noise Reduction Properties

Plazcryn sheets are used widely as noise reduction barriers along roads and highways. For more information see Plazcryn Acoustic Walls Manual.

4.5 Typical Properties – Plazcryl – Extruded Acrylic Sheets

Properties	Method	Units	Plazcryl (R7000)
General			
Density	ISO 1183	g/cm ³	1.19
Water Absorption	ISO 62 (1)	%	0.3
Mechanical			
Tensile Strength	ISO 527-2	MPa	72
Elongation at break	ISO 527-2	%	4
Tensile Modulus	ISO 527-2	MPa	3300
Flexural Strength	ISO 178	MPa	106
Flexural Modulus	ISO 178	MPa	3350
Compressive Strength	ISO 604	MPa	117
Rockwell Hardens	M scale		95
Impact Resistance (Charpy unnotched)	ISO 179/1fu	kJ/m ²	15
Impact Resistance (Charpy notched)	ISO 179/1eA	kJ/m ²	2
Impact Resistance (Izod notched)	ISO 180/1A	kJ/m ²	1.5
Optical			
Refractive Index	ISO 489		1.49
Light Transmission	ASTM D1003	%	92
(3mm transparent sheet)	ASTM D1003	%	< 1
Thermal			
Vicat Softening Temp.(50N)	ISO 306	°C	105
Heat Deflection Temp. (1.82 MPa)	ISO 75-1	°C	95
Coeff. of Linear Thermal Expansion (0-50°C)		µm/m°C	65
Thermal Conductivity	ASTM C177	°C	0.19
Maximum Continuous Service Temp.		°C	70
Maximum Short Time Service Temp.		°C	90
Minimum Temp.		°C	-40
Mechanical			
Dielectric Strength	DIN 53481	kV/mm	20-30
Dielectric Constant (50Hz)	DIN 53483		3.7
Dissipation Factor tanδ (50Hz)	DIN 53483		0.04
Surface Resistivity	IEC 60093	Ohm	>10 ¹⁴
Volume Resistivity	IEC 60093	Ohm•cm	>10 ¹⁵

4.6 Typical Properties – Plazcryl Super – Extruded High Impact Acrylic Sheets

Properties	Method	Units	S25 (R7700)	S30 (R7400)	S50 (R7500)	S75 (R7800)	S100 (R7600)
General							
Density	ISO 1183	g/cm ³	1.19	1.19	1.18	1.17	1.16
Water Absorption	ISO 62 (1)	%	0.3	0.3	0.3	0.3	0.3
Mechanical							
Tensile Strength	ISO 527-2	MPa	57	54	50	45	40
Elongation at break	ISO 527-2	%	22	26	30	35	40
Tensile Modulus	ISO 527-2	MPa	2450	2275	2100	1900	1700
Flexural Strength	ISO 178	MPa	88	84	79	71	62
Flexural Modulus	ISO 178	MPa	2470	2285	2100	1950	1800
Rockwell Hardens	M scale		77	73	68	56	44
Impact Resistance (Charpy unnotched)	ISO 179/1fu	kJ/m ²	51	59	67	71.5	76
Impact Resistance (Charpy notched)	ISO 179/1eA	kJ/m ²	4.3	5.3	6.2	6.9	7.6
Impact Resistance (Izod notched)	ISO 180/1A	kJ/m ²	4	4.5	5	5.6	6.3
Optical							
Refractive Index	ISO 489		1.49	1.49	1.49	1.49	1.49
Light Transmission	ASTM D1003	%	92	92	92	92	92
(3mm transparent sheet)	ASTM D1003	%	< 2.7	< 2.7	< 2.7	< 2.7	< 2.7
Thermal							
Vicat Softening Temp. (50N)	ISO 306	°C	99	98	97	94	90
Heat Deflection Temp. (1.82 MPa)	ISO 75-1	°C	92	91	90	85	83
Coeff. of Linear Thermal Expansion (0-50°C)		µm/m°C	70	80	100	105	110
Maximum Continuous Service Temp.		°C	65	63	63	62	62
Maximum Short Time Service Temp.		°C	86	83	81	76	74
Minimum Temp.		°C	-20	-20	-20	-20	-20

4.7 Chemical Properties

Plazcryn sheets have good resistance to water, alkalis, aqueous inorganic salt solutions and most common dilute acids. Some substances do not produce any effect on Plazcryn, some cause staining, swelling, crazing, weakening or dissolve it completely. The chemical resistance table below gives an indication of the chemical resistance of Plazcryn to a range of common chemicals, judged by visual examination of small unstressed samples immersed in various liquids at 20°C. This information should be used with caution since the performance of articles is influenced by temperature and by stresses applied to the material when machined or thermoformed or under service conditions. In case of doubt, it is recommended that appropriate tests be carried out to simulate the actual service conditions of the intended application. Please contact PLASKOLITE for information regarding special applications.

IMPORTANT NOTE:

Any substance that comes with contact with PMMA should be checked for compatibility. Even if the supplier confirms that the material is suitable for PMMA, please apply it first to a hidden area to see if there are any effects. However this will cover you for short-time effects only. To assess long-term effects of substances on PMMA, laboratory testing is required.

Chemical	Concentration	Compliance(dB)
Acetaldehyde		Dissolved
Acetic acid		Dissolved
Acetic acid	10% aqueous	Not affected
Acetic anhydride		Affected
Acetone		Dissolved
Acetonitrile	Aqueous	Dissolved
Ammonia		Dissolved
Ammonium chloride	Saturated	Affected
Amyl acetate		Dissolved
Aniline		Dissolved
Benzaldehyde		Dissolved
Benzene		Dissolved
Benzyl alcohol		Dissolved
Butyl acetate		Dissolved
Butyl alcohol		Dissolved
Calcium chloride	Saturated	Not affected
Carbon dioxide		Not affected
Carbon disulfide		Dissolved
Carbon tetrachloride		Dissolved
Chlorine	2% aqueous	Affected
Chlorine	Gas	Not affected
Chlorine	Conc.	Not affected
Chlorobenzene		Dissolved
Chloroform	Saturated	Dissolved

Chemical	Concentration	Compliance(dB)
Chromic acid	10% aqueous	Not affected
Chromic acid		Dissolved
Citric acid		Not affected
Cyclohexane		Dissolved
Cyclohexanone		Dissolved
Dibutyl phthalate		Affected
Dichloride		Dissolved
Diesel oil		Not affected
Diethyl ether		Dissolved
Diethyl phthalate		Affected
Epichlorohydrin		Dissolved
Ethyl acetate		Dissolved
Ethyl alcohol	10% aqueous	Not affected
Ethyl alcohol	50% aqueous	Affected
Ethyl alcohol		Dissolved
Ethyl dichloride	90% aqueous	Dissolved
Ethylene glycol		Not affected
Formaldehyde	40% aqueous	Not affected
Formic acid	10% aqueous	Not affected
Formic acid		Dissolved
Glycerin		Not affected
Hexane		Not affected
Hydrochloric acid		Not affected
Hydrofluoric acid	90% aqueous	Dissolved
Hydrogen peroxide	10% aqueous	Not affected

Chemical	Concentration	Compliance(dB)
Hydrogen peroxide		Dissolved
Isopropyl alcohol	Up to 30%	Dissolved
Isopropyl alcohol	50% aqueous	Affected
Lactic acid		Not affected
Lanoline		Not affected
Methyl alcohol		Dissolved
Methyl alcohol	50% aqueous	Not affected
Methyl alcohol	10% aqueous	Affected
Methyl ethyl ketone		Dissolved
Methyl salicylate		Dissolved
Nitric acid	95% aqueous	Dissolved
Nitric acid	10% aqueous	Not affected
Nitrobenzene	98% aqueous	Dissolved
Nitrogen		Not affected
n-octane		Affected
Olive oil		Not affected
Oxygen		Not affected
Paraffin		Not affected
Phosphoric acid		Dissolved
Phosphoric acid	10% aqueous	Not affected
Potassium hydroxide	Saturated	Not affected

Chemical	Concentration	Compliance(dB)
Salt water		Not affected
Silicone F110		Affected
Silicone F130		Affected
Silicone R220		Affected
Sodium carbonate	Saturated Saturated Saturated	Not affected
Sodium chlorate	40% aqueous	Not affected
Sodium hydroxide		Not affected
Sodium thiosulfate		Not affected
Sulfuric acid		Dissolved
Sulfuric acid	30% aqueous	Not affected
Sulfuric acid	10% aqueous	Not affected
Tetrahydrofuran		Dissolved
Tetraline		Dissolved
Toluene		Dissolved
Trichloroethane		Dissolved
Trichloroethylene		Dissolved
Turpentine oil		Not affected
Water		Not affected
Xylene		Dissolved

4.8 ESC (Environmental Stress Cracking)

ESC (Environmental Stress Cracking) is a well-known phenomenon in plastics including PMMA, and a common reason of product failure. ESC is a result of the combination of stress and chemical exposure. Under harsh chemical environment, stressed sheets will fail by cracking and crazing. The level of stress needed for ESC is lower than the normal failure mechanical stress of PMMA in a chemical-free environment. Stresses can be induced during forming and fabrication. These can be eliminated by an annealing process (see machining and forming instructions). Stresses can be induced also by improper installation (see installation instructions). Cold bended sheets under permanent induced stress or sheets under periodic stress (fatigue) are also susceptible to ESC.

4.9 Heat Transmission

The U-Factor, or overall heat transmission coefficient, is the amount of heat which will pass through one square meter in one second for a specific thickness of material. The following table presents the summer and winter U-Factors for horizontal and vertical installations.

W/m ² °C	Vertical Installation		Horizontal Installation	
Sheet Thickness	Summer Conditions	Winter Conditions	Summer Conditions	Winter Conditions
3 mm	5.56	6.01	4.48	6.52
4.5 mm	5.33	5.78	4.31	6.18
6 mm	5.1	5.5	4.19	5.9
12 mm	4.31	4.59	3.68	4.93
24 mm	3.34	3.51	3.0	3.74
30 mm	3.28	3.36	2.9	3.51

Total Heat Loss or Gain through a Window Due to Conduction/Convection:

Heat Loss = Window Area X [Indoor Temp - Outdoor Temp] X U-Factor

4.10 Solar Transmission

The Sun spectrum that reaches the earth surface ranges roughly from about 250nm to 2500nm wavelength. This spectrum can be divided in three regions of increased wavelength. The ultra-violet (UV) region below 400 nm, the visible region between 400 and 700nm and the infrared (IR) region above 700 nm. Plazcryl transparent sheets block partially the UV and transmit visible light and IR radiation. For special applications where more UV or IR blocking is needed, special products that block the UV (Plazcryl UV block) and the IR (Plazcryl IR Solar) have been developed.

FIGURE 1 – PLAZCRYL CLEAR SOLAR TRANSMISSION

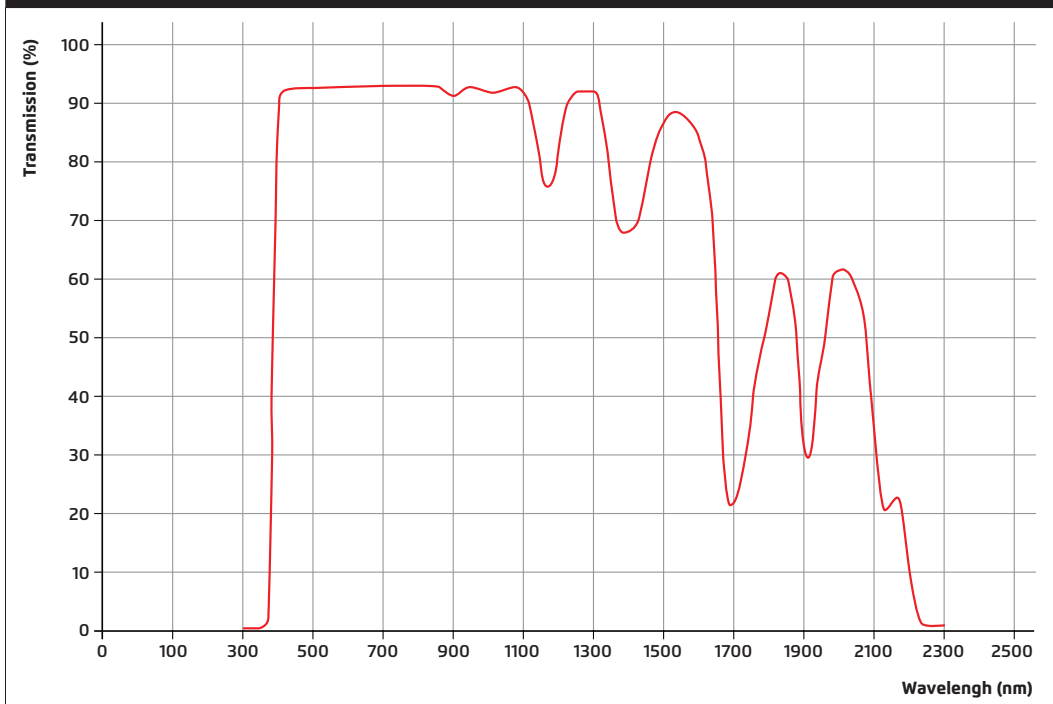

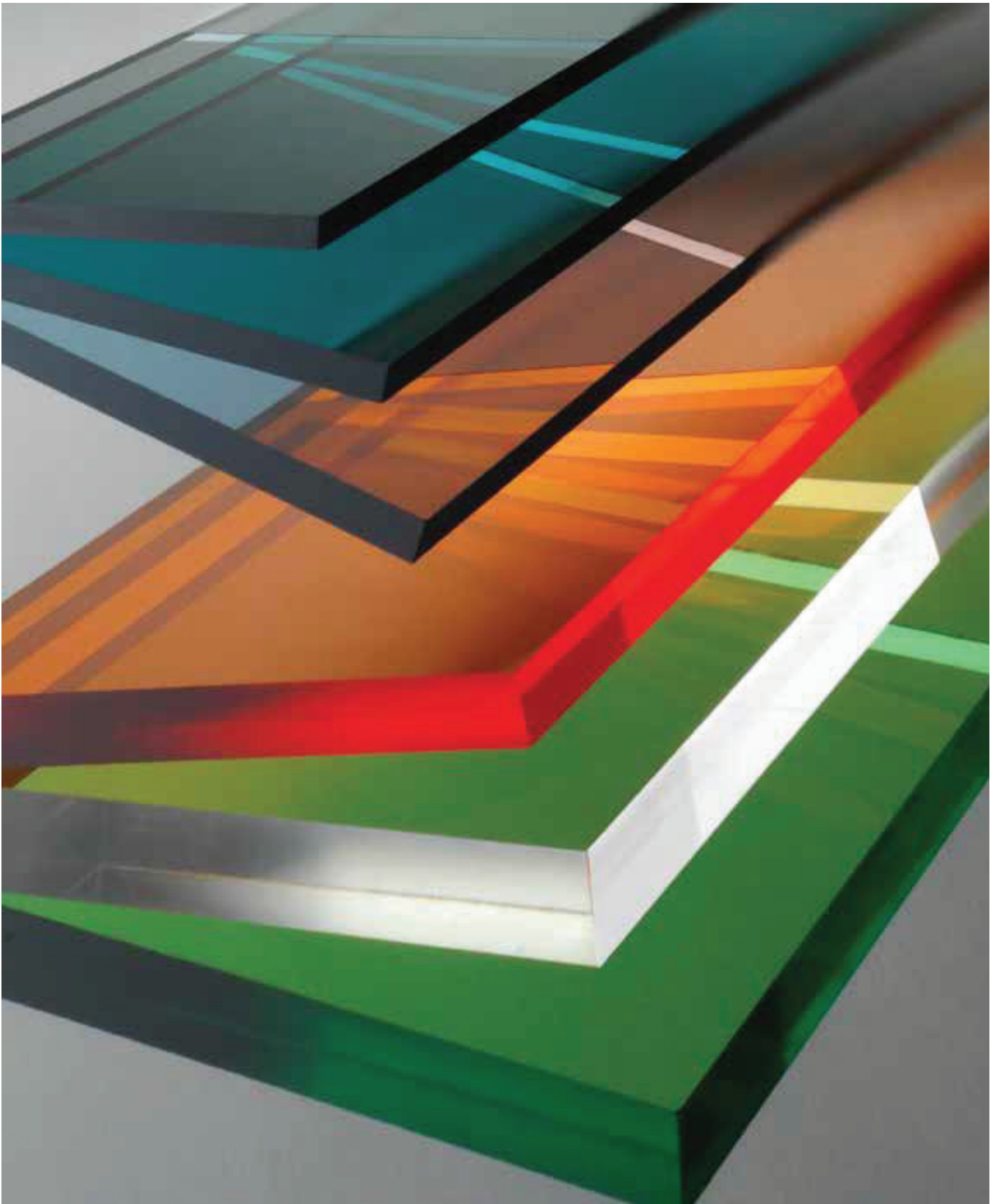

Special Grades

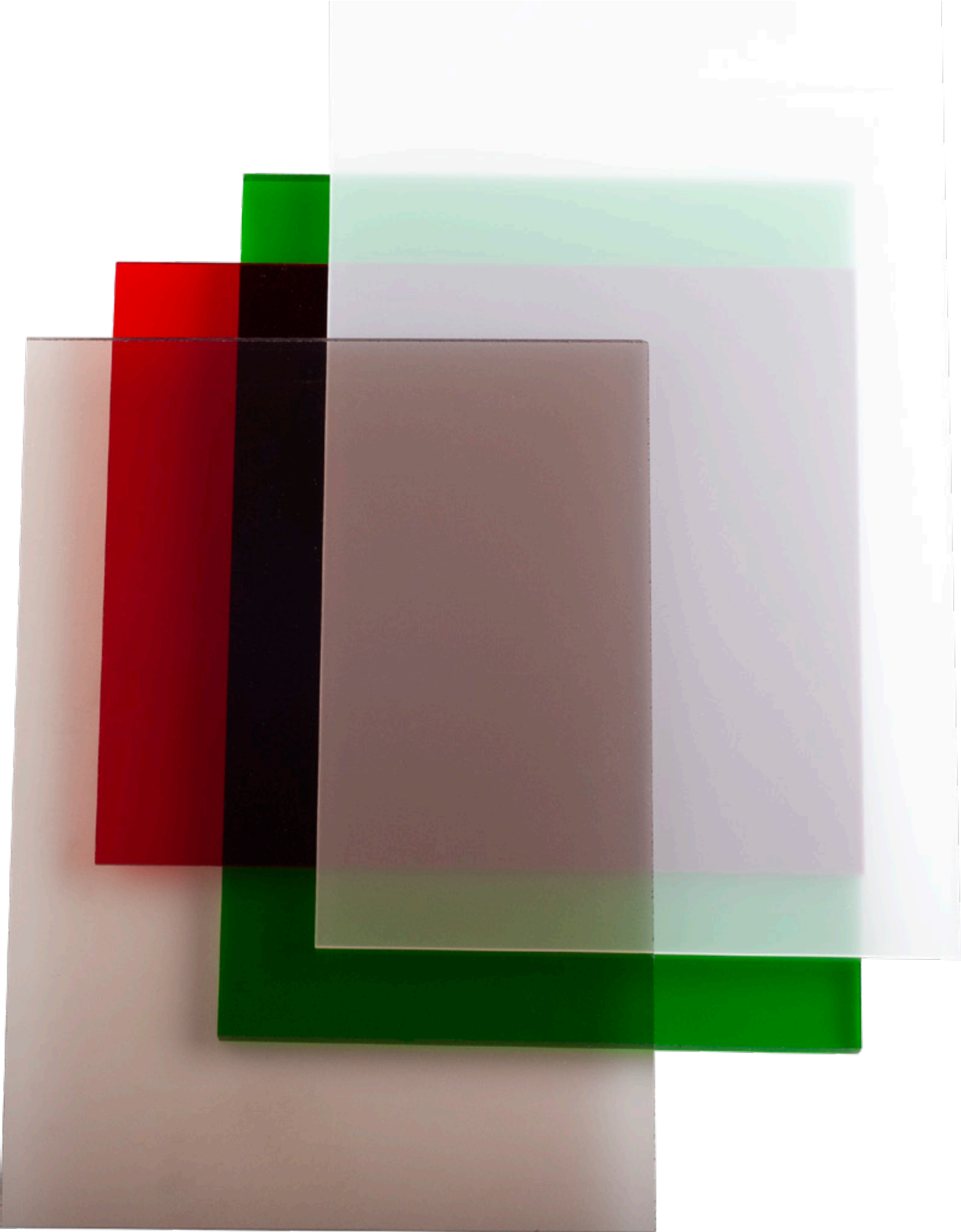

5. Plazcryn Special Grades

5.1 Plazcryn Embossed Sheets

Plazcryn sheets are available in a wide range of embossed patterns. Beside their beautiful esthetic appearance, the embossed patterns diffuse light by physical action providing an excellent solution for lightning applications. Embossing patterns include:

Pattern type	Maximum width (mm)	Maximum length (mm)	Thickness range (mm)
Pinspot	1,500	up to 6,000	1.5 to 5
Aqua	1,400	up to 6,000	1.2 to 5
Geometric	1,400	up to 6,000	1.5 to 5
Lizard	2,050	up to 6,000	1.5 to 5
Cracked Ice	1,500	up to 6,000	2.5 to 5
Prismatic K-12	1,500	up to 6,000	2.8 to 5
G-Tec	2,050	up to 6,000	1.5 to 5
Non reflect	1,250	up to 6,000	1.2 to 3
K-10	1,400	up to 6,000	2.8 to 5

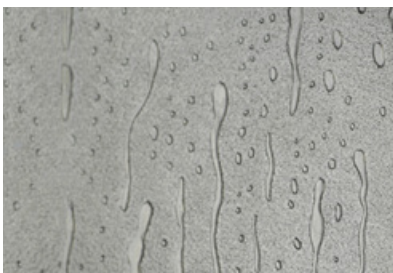

Aqua

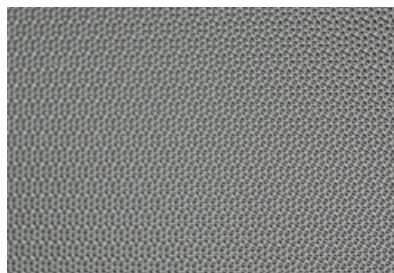

Pinspot

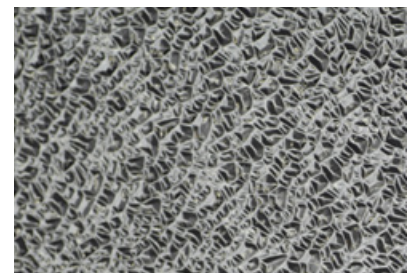

Cracked Ice

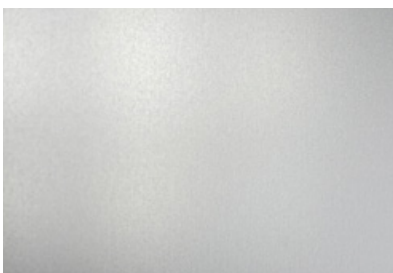

Non Reflective



G-Tec

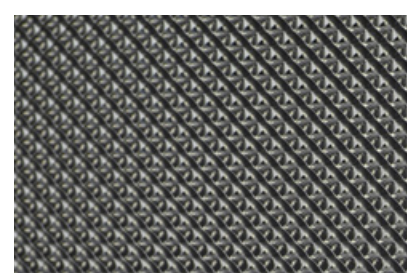

K-12

Plazcryl UV-Block

PMMA sheets transmit part of the UV light. Plazcryl UV-Block provides an excellent solution for any application that needs to maintain transparency while protecting against fading and yellowing due to UV radiation transmitted through the sheet. Applications include: museums, exhibitions, picture framing and windows. The Plazcryl UV-Block blocks 98% of the UV light from 300-380 nanometer, while keeping the outstanding intrinsic light transmission of the PMMA of about 92-93%.

FIGURE 2 – PLAZCRYL UV-BLOCK SOLAR TRANSMISSION

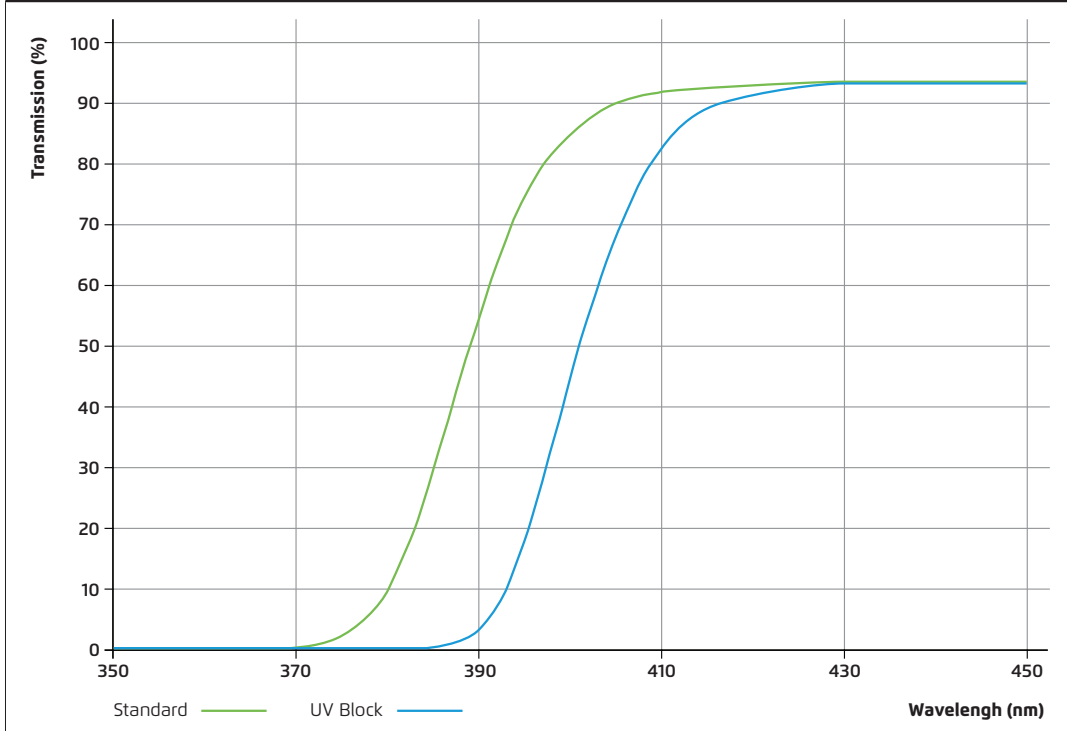

5.2 Plazcryn IR-Solar

Plazcryn IR-Solar helps to preserve energy, reduce cooling and heating costs. The solar near infrared (IR) radiation ranges from 700 to 2500 nanometers. These longer wavelengths are invisible to the eye, yet they contain about half of the solar energy. IR radiation builds up heat. The special formulation of Plazcryn IR reflects the undesirable hot IR radiation while allowing visible light to pass through.

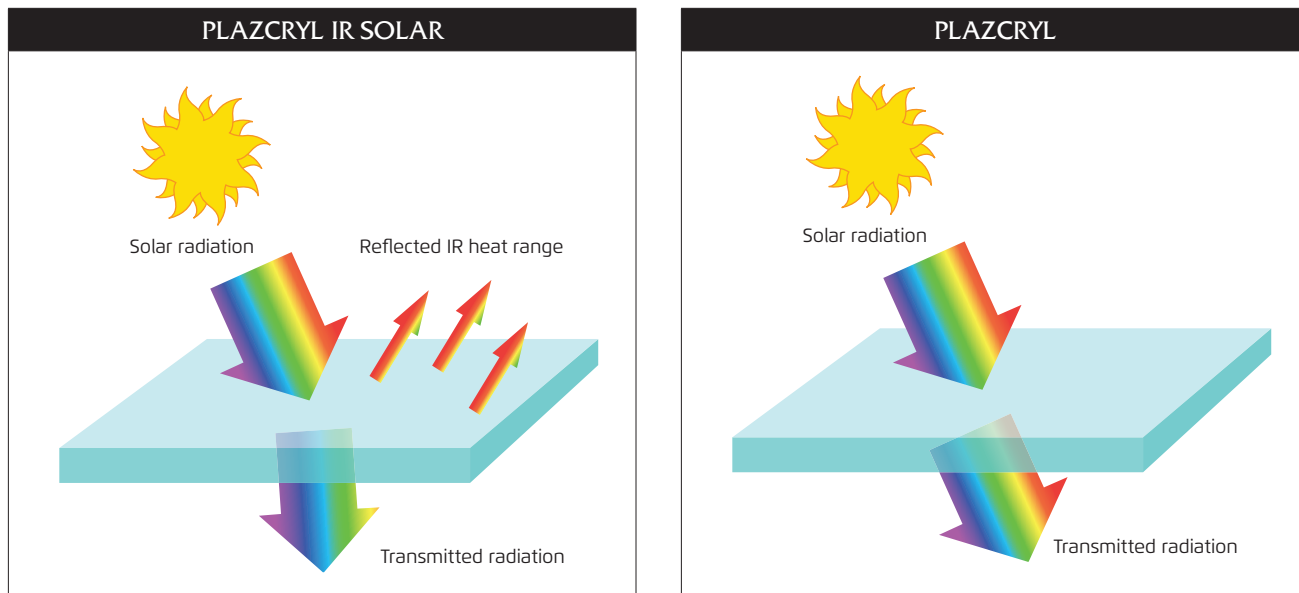

Typical solar properties of Plazcryn IR grades:

	LT (%)	Tsol (%)	SHGC	SC
Plazcryn Clear Standard (R7000)	93	84	0.86	1
Plazcryn IR-Solar Pearl (R7361)	51	30	0.40	0.46
Plazcryn IR-Solar Green (R7329)	58	30	0.47	0.55

- **LT:** Light Transmission
- **Tsol:** Solar Transmittance
- **SHGC:** Solar Heat Gain Coefficient - the ratio of solar heat gain through the sheet and the incident solar radiation. It takes into account all conduction, convection and radiation effects involved. The SHGC of a 3mm clear glass at normal (90°) incidence is 0.87.
- **SC:** Shading Coefficient is the ratio of SHGC of the sheet and the SHGC of a 3mm clear glass at normal (90°) incidence.

Measurements were performed according to ASTM E903 and ASTM E308 using a double beam spectrophotometer with a 100 mm integrating sphere.

5.3 Plazcryn Anti Glare (AG)

Plazcryn AG are Plazcryn extruded acrylic sheets with a hard and anti-glare coating. The coating increases the surface hardness to a level of 5H (pencil hardness) while reducing the glare reflection. The special coating formulation is UV protected and long lasting.

Plazcryn AG Glare Reflection (ASTM D523)	
20° angle	<10 gloss units
60° angle	<30 gloss units
85° angle	<20 gloss units

5.4 Acryled XT

LEDs are the most economical device in the field of illumination. They do not contain harmful elements like mercury, which is present in other illumination devices. LEDs are gaining popularity and are now replacing older illumination technologies. Unlike fluorescent or neon tubes, which have an angle of dispersion of 360°, LED's have a much narrower angle (from 40° to 140° for example) and appear as tiny spots of light. Acryled XT sheet from PLASKOLITE avoids this phenomenon known as „hot spots“ and optimized uniform diffusion without compromising light transmission. Acryled sheets transmit around 80% of the LED light (measured by luxmeter). Acryled XT sheet enables sign makers and designers to enjoy the benefits of LEDs and create elegant solutions that are cost and eco-efficient, whilst enhancing intensity and color.



5.5 Plazcryn Mirror and Top

Plazcryn Mirror sheets specially designed for mirror applications. Plazcryn Top are thin gauge highly optical Plazcryn sheets for electronic display applications. These sheets are produced using special materials in dedicated production lines with rigorous clean room environment and computerized state-of-the-art video quality control in order to detect the smallest defects in the sheets.



Machining

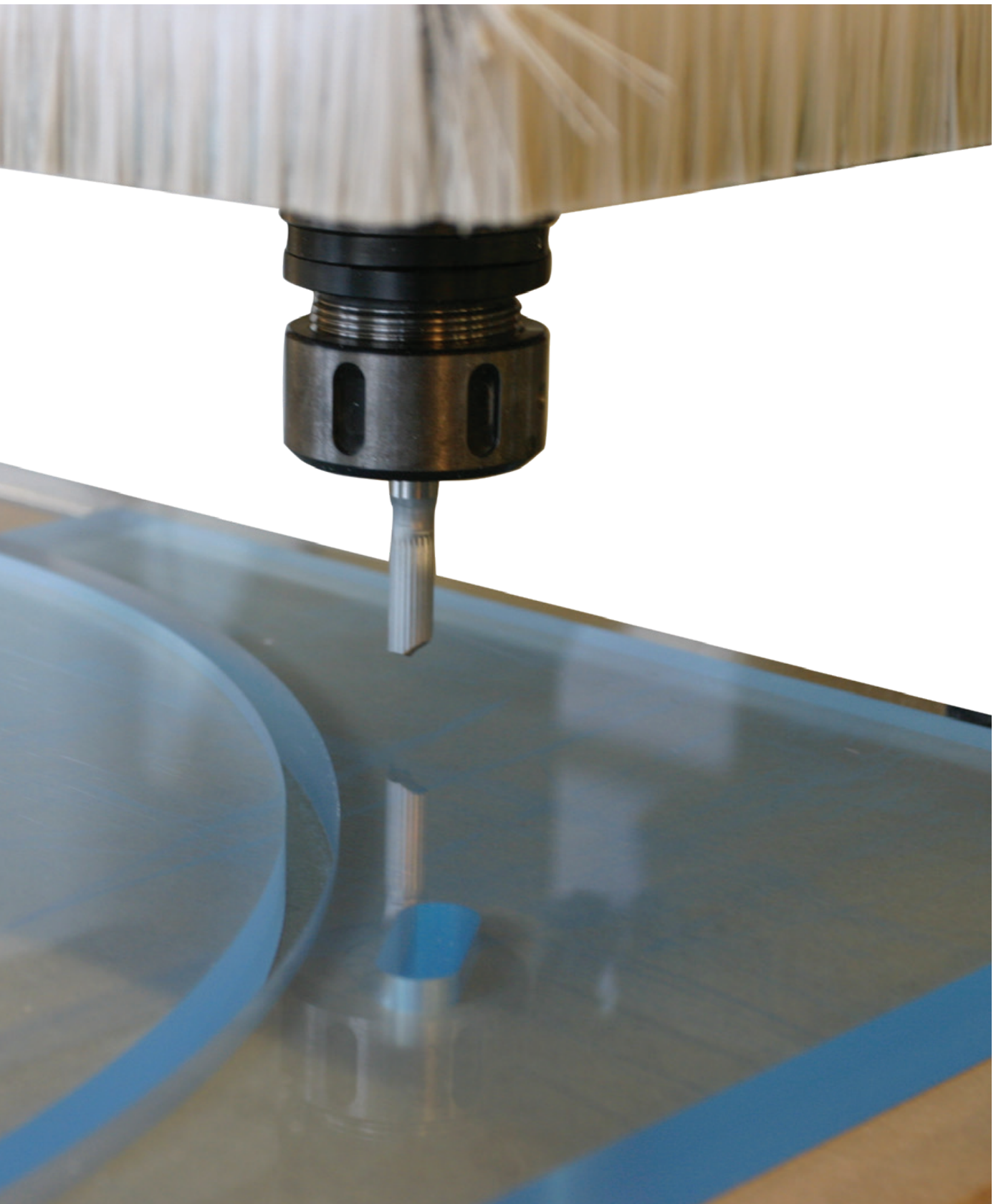

6. Machining Plazcryl Sheets

A wide range of artistic and industrial processes can be used to machine (cut, mill, turn, drill) Plazcryl sheets. Machining Plazcryl with plastic machine tools is recommended, but in their absence, Plazcryl can be machined using either wood or metal machine tools.

6.1 Basic Rules for Machining Plazcryl

All methods of machining cause local overheating, generating internal stress, which can result in crazing (very fine cracks) later evolving into larger cracks, during forming or in the presence of solvents (for example during bonding or painting).

Crazing can be significantly reduced if the following general instructions are applied.

- **Proper Cooling** - Keep the working tools cooled with compressed air. Beware from using coolants that can chemically attack PMMA. PMMA will soften if heated above 80°C.
- **Swarf Removal** - Ensure efficient removal of swarf. Machining without suction – requires frequent stops for manually cleaning the swarf.
- **Sharpened Tools** - Use only adequate tools and keep them perfectly sharp.
- **Material Support** - Support the sheet firmly during machining, especially close to the machined area, to avoid vibration of the sheet.
- **Feed Rate** -
 - The faster the feed rate is, the better the cut, but when the tool exceeds a certain speed the sheets start to chip, therefore the speed should be a little slower than this “chipping speed”.
 - Maintain as constant feed rate as much as possible.
- **Rotation Plane** - Keep the rotation plane of the working tool exactly parallel or perpendicular (depending on the machine used) to the feed direction.
- **Annealing** - Anneal the sheets before exposure to solvents or excessive temperature changes.

6.2 Cutting

When choosing the equipment for cutting Plazcryl, a few factors must be taken into account:

- The complexity of the cut.
- The accuracy needed.
- The quantities needed (cost efficiency).
- The edge finishing that is needed.
- The process following the cutting operation.

Hand Cutting

Thin Plazcryl sheets (up to 4 mm thickness) can be cut using a scoring knife. Draw the scoring knife along a ruler held firmly in place. Score several times applying very light pressure, at least 1/3 way through Plazcryl thickness. Align the cut with a straight edge (for example, a table edge) and apply gentle pressure, on both sides of the cut, starting at one end of the sheet, working your way slowly along the cut until full breakage is achieved.



Jigsaw

Plazcyl sheets up to 6 mm thickness can be cut by jigsaw, but results may be poor. Cutting Plazcyl with jigsaw results in inaccurate cuts and very rough edges. This type of cutting also causes high internal stress and will often cause melting and welding of the cut.

It is recommended to take note of the following guidelines to obtain best results:

- A fine tooth saw with 4-5-teeth/cm is recommended.
- The blade must be kept perpendicular to the sheet.
- Vibration of the sheet, during sawing, must be avoided, therefore a firm support, especially close to the machined area, is required.
- High but steady advance speed will reduce the chances of melting. Allow the blade to stop before withdrawing it from the cut.

Band Saw

Although nice clean edges can never be achieved with a band saw, these types of saws are very easy to operate and are the most cost efficient method for cutting curved sections, and trimming excess material from thermoformed parts before final machining.

It is recommended to take note of the following guidelines to obtain best results:

- The thickness of the blade should be 0.5-1.2 mm.
- The width of the blade will range from 5 to 50 mm. A narrow blade will allow a curved cut with a smaller radius but with a poorer quality.
- Use a saw blade with no side-set teeth.
- Slow but steady advance speed will reduce the chances of melting.
- Avoid blade twisting by keeping the saw guides as close as possible.
- Use the blade speed as per the recommendation in table below.

Thickness (mm)	Blade speed (m/min)	Saw pitch (teeth/cm)
Up to 3	1200-1500	8-10
3-10	1000-1200	3-6
Over 10	750-1000	2

Circular saw

Using this saw, it is possible to achieve a straight accurate cut with a clean edge. The edge is matt but simple polishing will restore its bright finish. Fixed table and moving cutting head machines are far more accurate and easy to handle and therefore perform better than stationary motor /moving table saws. Working with saw blades, which were designed especially for acrylic will have best results but in their absence, standard woodworking blades can be used.

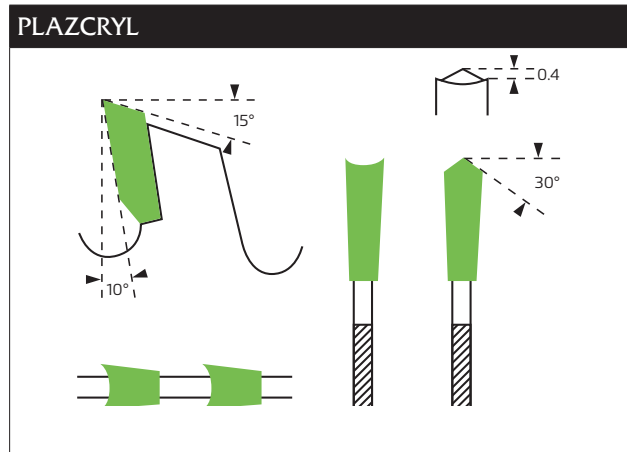

Plazcryl sheets from any thickness can be cut this way. Many factors influence the performance of cutting. Only by experimenting with them all, the best quality will be achieved.

The following parameters are recommended:

	Range
Saw thickness (mm)	2.8 - 5.0
Blade diameter (mm)	300 - 450
Number of teeth	60 - 80
Saw speed (rpm)	2500 - 4000
Saw advance (m/min)	15 - 18
Saw blade projection (mm)	15 - 35

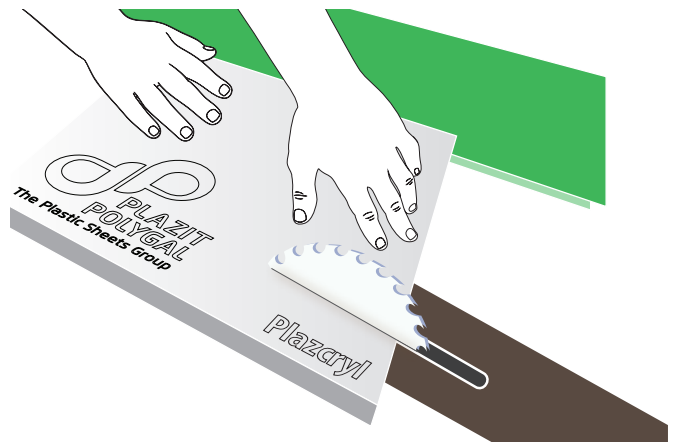

Electrical Cutting - Troubleshooting

Sheet breakage

Possible cause	Possible solution
Excessive vibration	Support the sheet properly, especially close to the cut

Chipping

Possible cause	Possible solution
Blunt blade	Replace blade with a sharp blade
Wrong blade type	<ul style="list-style-type: none">• Use a blade with characteristics according to the instruction in this guide• Use a blade with more teeth per cm
Blade too thin	Use a wider blade
Wrong blade projection	Adjust the blade projection to 15-35 mm
Advance speed too high	Decrease the advance speed
Rotation speed too low	Increase the rpm

Melting

Possible cause	Possible solution
Blunt blade	Replace blade with a sharp blade
Wrong blade type	<ul style="list-style-type: none">• Use a blade with characteristics according to the instruction in this guide• Use a blade with more teeth per cm
Advance speed too low	Use a wider blade
Rotation speed too high	Adjust the blade projection to 15-35 mm

White cutting edges

Possible cause	Possible solution
Blade is not parallel to the cut	Adjust the blade or the blade's carriage to be perfectly parallel with the feed direction

Blade-exit chipping

Possible cause	Possible solution
Cutting-out-flow-speed too high	Decrease the cutting-out-flow-speed

Sheets welding

Possible cause	Possible solution
Melting when cutting more than one sheet at a time	See melting problems and solutions

Crazing

Possible cause	Possible solution
Contact with chemicals, even in vapor form	Remove any chemicals close to the working area

6.3 Laser Cutting

Plazcryn, up to 20 mm thick, may be laser cut to make complex shapes. Laser cut results in a very accurate clean polished cut but with high internal stresses, which must subsequently be relieved by annealing if the product is to be exposed to solvents or paints. Many factors influence the performance of laser cutting. Only by experimenting with them all, the best quality will be achieved.

The major factors that influence the quality of the laser cut are:

- **Power of the laser** - The stronger the power, the deeper or quicker you can cut.
- **Laser focusing** - If you are out of focus, you have to burn through more material, and it will take longer. Cutting thick materials may require a delicate balance between the need for a focused beam and a wide gap so the edges don't stick back together when the cut is finished.
- **Speed of the cut** - The speed that the laser is moved over the material determines how much burning power is applied to any one spot. At a given speed a deeper cut requires a more powerful laser beam.
- **Pulses per cm** - This is another factor determining the power applied to any one spot.
- **Thickness of material** - The thicker the material, the more power it takes to cut it. Good focusing and the number of times the laser beam is passed over the sheet, are the key to a good cut of thicker materials.
- **Number of passes** - The more the laser beam is passed over the sheet, the deeper the cut.
- **Proper cooling** - An air jet, directed at the cutting point, might be needed to prevent flaming and in some cases will help in achieving a cleaner cut.
- **Consistent ventilation of the smoke and vapor.**

Changing one factor will affect another. Finding the right combination requires a lot of practice. Optimal performance depends on the laser machine. For more specific details consult with your laser machine manufacturer.

IMPORTANT NOTE:

When laser cutting Plazcryn, provide adequate ventilation at the cutting head to remove any trace of unpleasant combustion vapor.



6.4 Drilling

As in the case of saws blades, working with drills and bits that were designed for plastics will have the best results, but in their absence, modified woodworking drill bits can be used.

Modifying standard woodworking drill bits to fit acrylic consist of three stages.

1. Grind the tip angle of the bit to 60°-90°.
2. Grind the cutting edge to be parallel to the bit's length line.
3. Grind a clearance angle of 12°-15°.

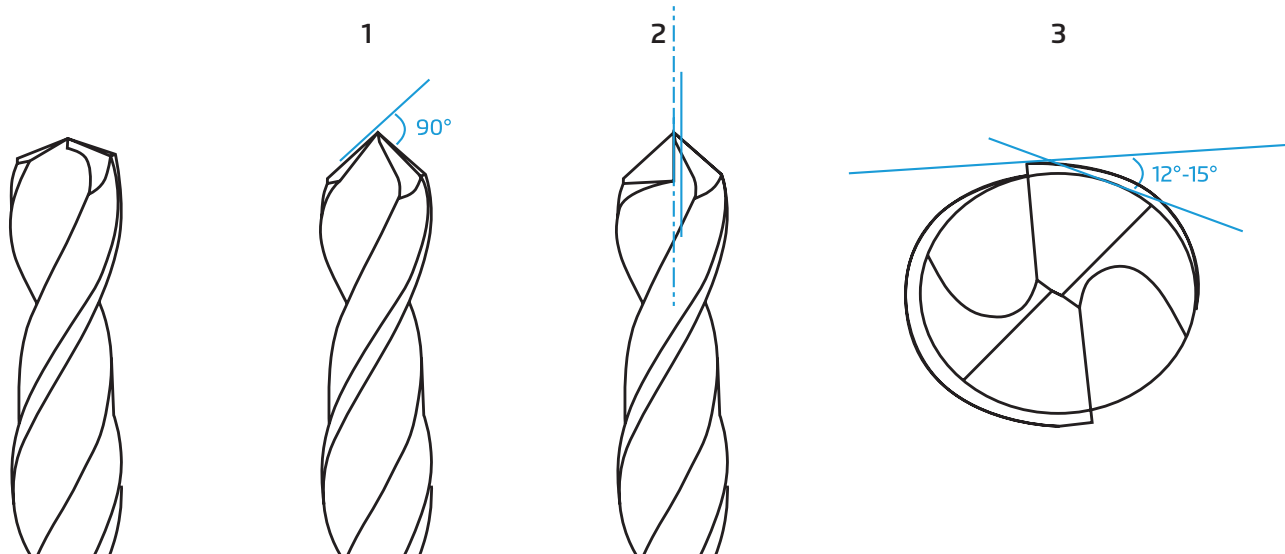

It is recommended to observe the following guidelines to obtain best results:

- To prevent chipping the sheet should be backed with either a piece of scrap Plazcryn or a piece of hard wood so that the drill bit continues into solid material as it exits the bottom surface.
- A center punch should not be used to mark the position of the hole, as this will crack the Plazcryn. When drilling with a greater diameter than 10 mm, a small pilot hole should be drilled first to locate the drill.
- The drill bit must be kept vertical to the sheet.
- When drilling a hole three times deeper than the diameter, back feed the drill at regular intervals to ensure removal of swarf.
- Suggested speed in rpm = 11,000/Drill diameter in mm.
- Maintain a slow constant feed rate (use a slower feed rate as the bit enters and exits the Plazcryn). Do not stop the drill before withdrawing from the drill hole.

Drilling - Troubleshooting

Sheet breakage

Possible cause	Possible solution
Excessive vibration	Support the sheet properly, especially close to the drill
High pressure application	Apply very light pressure
Wrong bit withdrawn	Withdraw the drill bit slowly and stop the rotation only after full withdrawal

Chipping

Possible cause	Possible solution
Wrong drill bit	Use a drill bit with characteristics according to the instruction in this guide
Blunt drill bit	Replace the drill bit with a sharp drill bit
Curved drill bit	Replace the drill bit
Excessive vibration	Support the sheet properly, especially close to the drill
Advance speed too high	Decrease the advance speed
Rotation speed too low	Increase the rpm
Bit diameter too big	Drill a pilot hole

Bit-exit chipping

Possible cause	Possible solution
Insufficient back support	Use wood or scrap Plazcryn to back support the drill

Melting

Possible cause	Possible solution
Blunt bit	Replace the drill bit with a sharp drill bit
Curved drill bit	Replace the drill bit
Advance speed too low	Increase the advance speed
Rotation speed too high	Decrease the rpm
Insufficient cooling	Cool with air and back feed the bit more frequently

Crazing

Possible cause	Possible solution
Contact with chemicals, even in vapor form	Remove any chemicals close to the working area

6.5 Routing

Routing Plazcryn with Standard CNC, table or even hand routers produces a better edge than other mechanical machining. Bits designed especially for routing acrylic are commercially available and will perform the best.

Routing Plazcryn is a very complex task comprising of a number of variables:

- **Bit selection** - The geometry of the cut, especially minimum inside radius, define the required diameter of the bit. The bit type is chosen according to the geometry, the depth and the required finish of the cut. It may well be that two types of bits are required for one job, the first one for fast, rough cutting and the second for good quality finishing of the cut.
- **Cutting parameters** - The cutting performances are highly sensitive to the spindle speed, feed rate and maximum cut depth per pass, thus making it very hard to find the best combination by trial-and-error. It is advisable to first obtain the recommendation of the bit manufacturer for the parameters for every specific bit type. Typical spindle speeds are 16,000-20,000. Typical feed rates are 2-5 m/min. Cutting depth per pass should not exceed twice the diameter of the bit.
- **Feed direction** - Conventional cutting will usually result in a better quality cut than climb cutting. Since most routers turn clockwise, the feed direction should be counterclockwise for external edges and clockwise for inside edges. When for a specific bit the manufacturer recommends climb cutting, use the opposite direction to those mentioned above.
- **Cooling** - Routing Plazcryn is best done dry, therefore cooling and swarf removal with an air jet is recommended.
- **Vibrations** - The cutting performances are highly sensitive to vibration of both the sheet and the cutter. The sheet must be properly and firmly fixed by using vacuum or clamps. The Spindle, shaft collets and bearings must be clean and in perfect condition.

Routing - Troubleshooting

Chipping

Possible cause	Possible solution
Blunt bit	Replace the bit with a sharp bit
Excessive tool vibration	Check the collets, the bearing and the bit's shaft. Replace the defected part
Excessive sheet vibration	Support the sheet properly
Advance speed too high	Decrease the advance speed
Rotation speed too low	Increase the rpm

Tool breakage

Possible cause	Possible solution
Advance speed too high	Decrease the advance speed
Bit not properly installed	Fix the bit in collets and close it tight
Heavy chip load	<ul style="list-style-type: none"> • Increase number of flute • Ensure proper swarf removal
Excessive tool vibration	Check the collets, the bearing and the bit's shaft. Replace the defected part

Melting

Possible cause	Possible solution
Blunt bit	Replace the bit with a sharp bit
Advance speed too low	Increase the advance speed
Rotation speed too high	Decrease the rpm
Insufficient cooling	Cool with air and back feed the bit more frequently

Crazing

Possible cause	Possible solution
Contact with chemicals, even in vapor form	Remove any chemicals close to the working area

6.6 Engraving

Engraving Plazcryl is done with the same machinery as routing. The fine differences, separating engraving from routing, are listed below.

1. Use a small diameter cut head (2-6 mm).
2. Remove the PE protective film before engraving (It is recommended to place back the PE film, when the engraving process is over).
3. Typical spindle speed should be 9,000-10,000 rpm.
4. Typical feed rate should be 1-3 m/min.
5. Typical cutting depth, per pass 0.3 mm.
6. Anneal the engraved section before painting.

For general instructions about Laser engraving, see "Laser cutting" instructions.

Machining

6.7 Finishing

The finish obtained depends primarily on the smoothness of the machined surface. Machine marks can be removed by scraping or sanding resulting in a smooth but mat surface. To obtain gloss finish, polishing will be needed.

6.8 Scraping

Removal of machine marks as well as easing sharp edges can be done using steel scrapers with a sharp blade set at 90°.

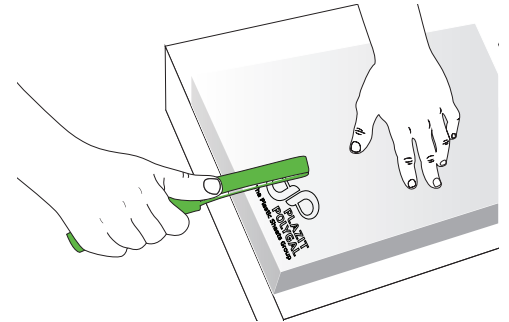

6.9 Sanding

Standard woodworking equipment is used to sand Plazcryn sheets. Bench, portable or belt sanders may be used to remove machine marks or saw cut marks from the edge of Plazcryn.

Sanders may be used to remove machine marks or saw cut marks from the edge of Plazcryn. Sandpaper with 150-400 grit is needed, but if polished later, it is recommended to sand Plazcryn with 600 or 1000 grit sandpaper. If Plazcryn is very deeply scratched a 3 stage sanding process might be needed. First, the deep scratches should be sanded using 80-100 grit paper, then a 400 grit paper should be used to remove the scratches from the coarse paper and eventually a 1000 grit paper should be used to prepare the surface for polishing. To prevent softening or melting of the surface, apply light pressure and keep either part or sander in constant circular motion. Sanding with sandpapers 150 grit or finer, should be done wet. After any sanding operation it will be necessary to anneal the part if bonding or surface decoration is intended.

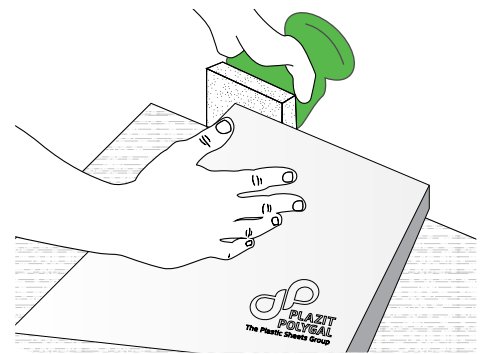

Hand Sanding

This technique is efficient only for sanding small areas or when power sanding is not possible, due to lack of equipment or inaccessible surface. Use a wooden or rubber sanding block. If the surface that is to be sanded is other than flat, the sanding block must have its mirror shape enabling to apply even pressure on all the sanded surfaces. Deep scratches should first be removed using 220-600 grit. To regain a smooth, almost glossy surface, 1000 grit grade waterproof sandpaper should be applied wet with light pressure and constant motion, preferably circular.

Sanding - Troubleshooting

Melting

Possible cause	Possible solution
Excessive heat	<ul style="list-style-type: none"> • Apply less pressure • Keep the part in constant movement

Burning

Possible cause	Possible solution
Excessive heat	<ul style="list-style-type: none"> • Apply less pressure • Keep the part in constant movement

Scratches on the sanded part

Possible cause	Possible solution
Paper too fine	First use a coarser paper and then finish with the finer one

Paper clogging

Possible cause	Possible solution
Excessive dust	Use plenty of water

6.10 Polishing

When polishing Plazcryl edges, all machine marks must be removed by scraping, sanding, routing or even by power buffing using a fast cutting abrasive buffing compound.

Don't glue polished edges. This will cause crazing.

Power buffing

Stationary and portable machines with rotating calico mops, bleached muslin or felt are used to polish Plazcryl. Apply mild abrasive buffing compound and light pressure. Keep the Plazcryl or the wheel in constant circular motion. When restoring the original gloss to Plazcryl surface, the polished area should be much larger than the damaged surface, to „feather“ the edges and avoid optical distortion.

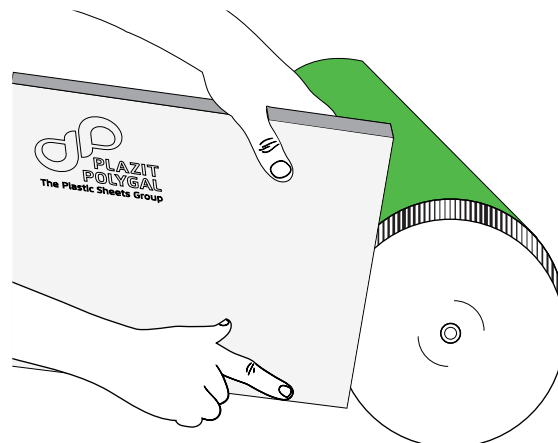

Power buffing - Troubleshooting

No polish is achieved

Possible cause	Possible solution
Insufficient rubbing	<ul style="list-style-type: none"> • Apply less pressure • Keep the part in constant movement
Insufficient buffing compound	Apply more buffing compound
Surface not sanded	Sand the surface according to the instructions

Optical distortion

Possible cause	Possible solution
Too small area	Polish a wider area and feather its edges

White edges

Possible cause	Possible solution
Excessive rubbing	<ul style="list-style-type: none"> • Apply less pressure • Decrease the speed of the wheel

Breaking

Possible cause	Possible solution
Chipped edges	Use only perfect cut and drilled sheets

Flame polishing

A standard hydrogen-oxygen torch as well as a small blowtorch type gas-air flame will produce a highly polished clean edge. A smooth Plazcryn edge, clean of machine marks, is essential for flame polishing. Adjust a narrow 5-10 cm long flame, and slightly pass the hottest part of the flame rapidly across the sheet. If the flame is moved too slowly, a mat surface, bubbles or even ignition of the surface can occur. While flame polishing will result in a highly polished edge on Plazcryn clear sheets, it might give a poor performance on certain Plazcryn colored sheets, resulting in a matt finish or discoloration. Annealing of the part will be necessary if the flame polished edges are to be bonded or decorated.

NOTE:

- Remove the PE protection from the flame polished area.
- Before flame polishing, please read the flame torch manufacturers safety notes.
- Plazcryn sheets are combustible (see section 3.1).

Hot air gun polishing

Hot air gun polishing will give the same results as in flame polishing. This process is almost as rapid as flame polishing but much less skill is required and it is far less hazardous. A smooth Plazcryn edge, clean of machine marks is essential also for this type of polishing. Adjust the temperature to 400-500°C at a distance of 10 cm and slightly pass the hot air flow rapidly across the sheet. If the hot air gun is moved too slowly, a mat surface or bubbles can occur.

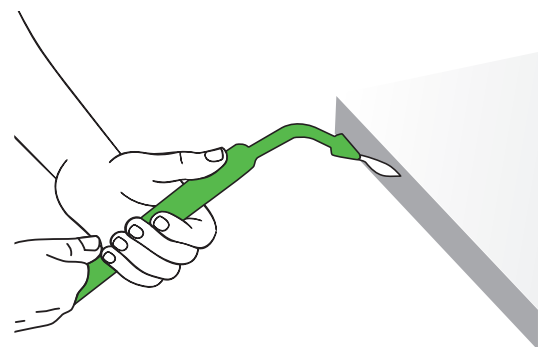

Flame & heat polishing - Troubleshooting

Mat surface

Possible cause	Possible solution
Excessive heat	Pass the heat source faster across the sheet

Bubbles

Possible cause	Possible solution
Excessive heat	Pass the heat source further from the sheet

Melting

Possible cause	Possible solution
Excessive heat	Use a lower temperature of the heat source

No polish is achieved

Possible cause	Possible solution
You gave up too soon	It usually takes a few attempts to obtain a perfect polish

Crazing

It is most recommended to anneal the heat-polished part

Diamond polishing

Edge finishing machines are commercially available. Using diamond-polishing machines is the fastest way for obtaining edge with a smooth and even glossy surface. This technique results in straight highly polished edges without the need for sanding or scraping.

6.11 Cold Bending

Unlike in the case of thermoforming, cold bended Plazcryn will not keep its form unless installed into a frame. The sheet must be with perfect edges to avoid breakage during bending. The radius of the bend should not be below the minimum value in order to avoid high permanent stress, which would eventually cause small cracks or even break the sheet.

Minimum recommended bend radius of 300 times the thickness of the sheet.

- For 2 mm sheets minimum radius is 600 mm.
- For 3 mm sheets minimum radius is 900 mm.
- For 4 mm sheets minimum radius is 1200 mm.
- For 5 mm sheets minimum radius is 1500 mm.
- For 6 mm sheets minimum radius is 1800 mm.

Cold bended sheets are at stress and special attention must be paid not to install them in environments with chemicals. The combination of high stress and chemical attack (ESC – Environmental Stress Cracking) may cause cracks and cloudiness.

Cold bending - Troubleshooting

Crazing

Possible cause	Possible solution
Radius of curve is too small	Enlarge the radius of the curve or use a thinner sheet
Contact with chemicals, even in vapor form	Remove any chemicals from the environment

Breaking

Possible cause	Possible solution
Chipped edges	Use only perfect cut and drilled sheets
Excessive Stress	Anneal the sheet especially if it is to be in presence of solvents

6.12 Thermoforming

Plazcryn softens with temperature allowing for easy thermoforming:

PLAZCRYL EXTRUDED ACRYLIC																	
TEMPERATURE (°C)																	
60	70	80	90	100	110	120	130	140	150	160	170	180	190	200	210	220	230

Thermoforming involves three stages:

1. **Heating** - softening Plazcryn until its plastic/soft phase.
2. **Forming** - forcing Plazcryn into the desired form.
3. **Cooling** - restoring Plazcryn its initial rigidity.

PLASKOLITE has developed a special PE masking film that can be left in position during heating and forming. However when deep thermoforming is needed it is recommended to remove the film before forming. When introducing the Plazcryn sheet to the thermoforming machine avoid scratching and indenting the sheet. Small hardly visible scratches and indentations in the sheet will expand and may become visible after thermoforming.

Safety note

Plazcryn sheet is combustible. Before heating Plazcryn, the necessary fire precautions must be considered, based on regional regulations and good judgment, taking into account the burning behavior of Plazcryn. When heating Plazcryn horizontally, extra care should be taken to prevent sagging on the heater causing damage and a possible risk of fire. Plazcryn surface temperature must not exceed 210°C, as this might cause flammable decomposition gasses to occur.

Pre-drying

Plazcryn can be thermoformed without pre-drying, however, if improperly stored or stored for a very long time, Plazcryn sheets can absorb moisture which will affect their thermoforming performance. Unlike other materials, moisture in Plazcryn during thermoforming doesn't result in degradation of the material but can affect the appearance of the part. The appearance of small bubbles in the sheet, after the heating process, is an indication that too much moisture was absorbed in Plazcryn and therefore the rest of the sheets must be pre-dried. Remove the protective film and pre-dry in a ventilated oven at 70- 80°C for a period of 1-2 hours per mm thickness.

Heating

If Plazcryn is formed before it is soft, stress is generated and reduction of mechanical properties leading to mechanical failure may occur. On the other hand, too much energy will melt the material, making it impossible to work with, or might even cause surface blisters. Hot spots may even cause local material degradation and reduction of mechanical properties. Care should be taken to ensure that Plazcryn is uniformly heated: temperature differences exceeding 5°C across the sheet may lead to internal stresses. The working area must be sealed from drafts. Wind will badly influence the results. Certain Plazcryn colors can change slightly during the heating process, specially is the sheet is overheated. Moreover, since the sheet is stretched due to drawing, there will be an inevitable thinning of the sheet, giving rise to a decrease of opacity (in opaque sheets) or an increase in light transmission (in translucent sheets) through the thinner area.

Hot-air circulation oven

This technique is characterized by the uniformity of heating and by its mass production capabilities. More than one sheet can be in the oven in different stages of heating, therefore it is the obvious choice of high volume producers. Temperature should be accurately controlled. For optical quality products sheets should be hung vertically to avoid any contact with a surface. Hang the sheets along their longest dimensions using suitable clamps.

Infrared heating

Infra-red inline heating machines (all three thermoforming stages done on the same machine) are the preferred option for heating Plazcryn. These machines have a heating head, which can be moved freely when the heating process is done, making room for the forming and cooling process. Although heating time is very short, the possibility to heat only one sheet at a time makes this method cost efficient only for low volume / high versatility production. Plazcryn of 5 mm thickness and above must be heated by a two-sides heating device. Two-sided infrared heating machines are preferable in all cases because they will cause a more uniform heating through the sheet thickness.

Heating conditions

The following factors should be taken into consideration when determining the temperature and time of the heating process:

- The sort of heating source (infrared or hot air circulation).
- The distance between the sheet and the heating source.
- The uniformity of the heating (on all three dimensions of the sheet).
- The material thickness.
- The type of mold.
- The depth and complexity of the required shape.
- Degree of stretching required.

	Hot air	Infrared
Minimum temperature (°C)	140	140
Maximum temperature (°C)	190	190
Recommended range (°C)	160-175	160-175
Heating time (s/mm thickness)	130-180	33-40 (one-side), 15-25 (two-sides)

Shrinkage

After heating, Plazcryl extruded acrylic sheets will shrink during the cooling process. The shrinkage is higher in the extrusion direction (MD - Machine direction).

When final part dimensions are critical, forms may be sufficiently oversized to allow for shrinkage when the part cools from ejection temperature to room temperature.

The table below details the shrinking percentage of two Plazcryl sheets:

1. Plazcryl standard - produced according to the shrinkage definitions of ISO standards.
2. Plazcryl for sky domes - lower shrinkage, produced upon special request, for use in thermoforming.

This characteristic of Plazcryl should be taken into account when planning the dimensions of the sheet.

Typical shrinkage values for Plazcryl sheets are:

Thickness (mm)	Standard		Sky Domes	
	Shrinkage M.D.	Shrinkage T.D.	Shrinkage M.D.	Shrinkage T.D.
1.80 - 2.30	6% - 7%	0.5%	3% - 4%	0.5%
2.30 - 3.50	5% - 6%	0.5%	2% - 3%	0.5%
3.50 - 4.00	3% - 4%	0.5%	1% - 2%	0.5%
4.00 - 6.00	2% - 3%	0.5%	0% - 1%	0.5%
> 6.00	2%	0.5%	0% - 1%	0.5%

M.D. - Machine (extrusion) direction

T.D. - Transverse (perpendicular to extrusion) direction

Forming

While in its soft phase, Plazcryl can be formed to almost any shape, by different methods and equipment. Home-made machines as well as sophisticated commercial machines can be used depending on the product requirements (complexity, quality and volume).

Line bending

Most common line bending simple equipment will give excellent results. Double side heating machines with cooling strips are recommended if a very accurate bend and high quality surface near the bend is needed. Ceramic and quartz tubes or even metal rod heaters equipped with a thermoregulator and installed with parallel support on both sides are most commonly used. The supports should keep Plazcryn at least 0.5 cm away from the heater. First, remove the PE Film from the bend line facing the heater then, lay Plazcryn on the supports with the bend line above the strip heater. Plazcryn is sufficiently heated when it slightly resists bending. Remove the sheet from the heater, place it in a fixture with the desired angle, clamp it and leave it to cool naturally. Line heating and bending of PMMA (as any other thermoplastic) induces stress into the material. Design and processing good practices will reduce the level of stress; however the properties of the material in the bent area will be unavoidable lower. Bent areas should be kept away from adhesives and chemicals that can produce ESC.

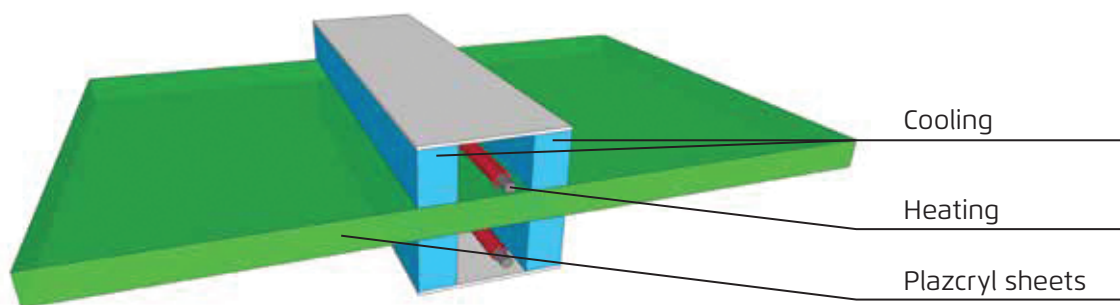

Please note the following points:

1. Avoid direct contact of Plazcryn with the hot strip heater.
2. Sheets of more than 5 mm thickness should be heated from both sides. If the two sides are not heated simultaneously, heat the outer side of the bend last.
3. If Plazcryn is to be acutely bent, make a 90° V-groove on the inner side of the bend prior to the heating.
4. A bend line longer than 1000 mm might bow across the bend. This can be improved if Plazcryn is bended perpendicularly to the machine direction.
5. The greater the diameter of the rod heater and the more the rod heater is distant from Plazcryn, the wider the heating zone, enabling formation of a bend with a larger radius.
6. The width of the heating zone should be:
bending Plazcryn up to 90° - 3 times the thickness.
bending Plazcryn more than 90° - 5 times the thickness.
7. Avoid contact of the heated Plazcryn with hard rough surfaces. Felt, flannel or aluminum can be used to cover the surface of the fixture, to help prevent stamping.
8. Anneal the bent part before exposure to solvents or excessive temperature changes.

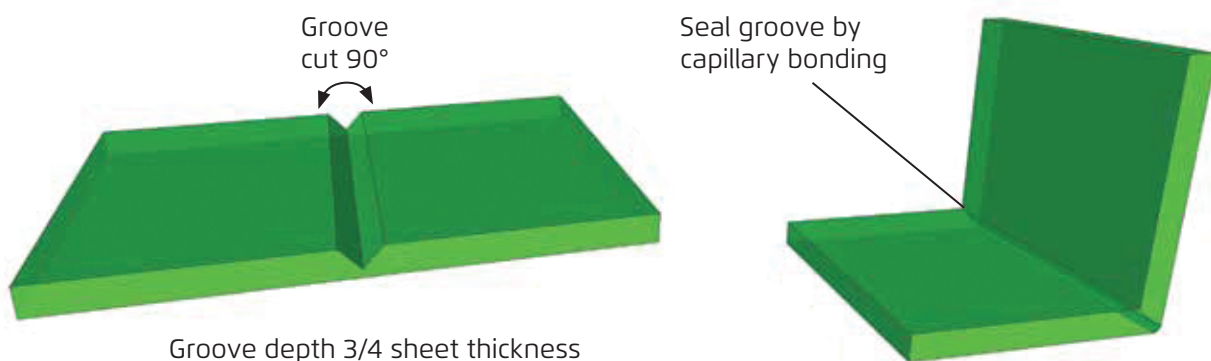

Hot line bending - Troubleshooting

Blisters on the surface of the sheet

Possible cause	Possible solution
Overheating	<ul style="list-style-type: none">• Shorten the heating time• Lower the heaters temperature• Increase distance between sheet and heating source

Bubbles in the sheet

Possible cause	Possible solution
Moisture in the sheet	Pre-dry the sheet before hot bending

Radius of bend too wide

Possible cause	Possible solution
Heated zone too wide	<ul style="list-style-type: none">• Use a heater rod with smaller diameter• Lay the sheet closer to the heater

Edges swell

Possible cause	Possible solution
Sheet too thick	<ul style="list-style-type: none">• Make V shape cut• Use a thinner sheet

Crazing

Possible cause	Possible solution
Heated zone too narrow	<ul style="list-style-type: none">• Use a heater rod with bigger diameter• Increase distance between sheet and heating source
Excessive stress	Anneal the bent part
Contact with chemicals, even in vapor form	Remove any chemicals close to the working area

Crossbow bend

Possible cause	Possible solution
The sheet is too wide	Bend the sheet perpendicularly to machine direction

Drape forming

This method of forming is restricted to two dimensional or very simple three dimensional shapes, which require no stretching for forming. Heat Plazcryn properly between 140°C and 150°C and without delay, drape it over the mold. In drape forming it is crucial that Plazcryn is placed on the mold at the right temperature. If not hot enough, Plazcryn will not obtain its shape but if too hot, it will curl and twist. Plazcryn will often obtain its form by the force of its own weight but in some cases the help of some forcing is needed. The hot edges of Plazcryn tend to curl and therefore clamping or heavy covering should force the edges to the mold.

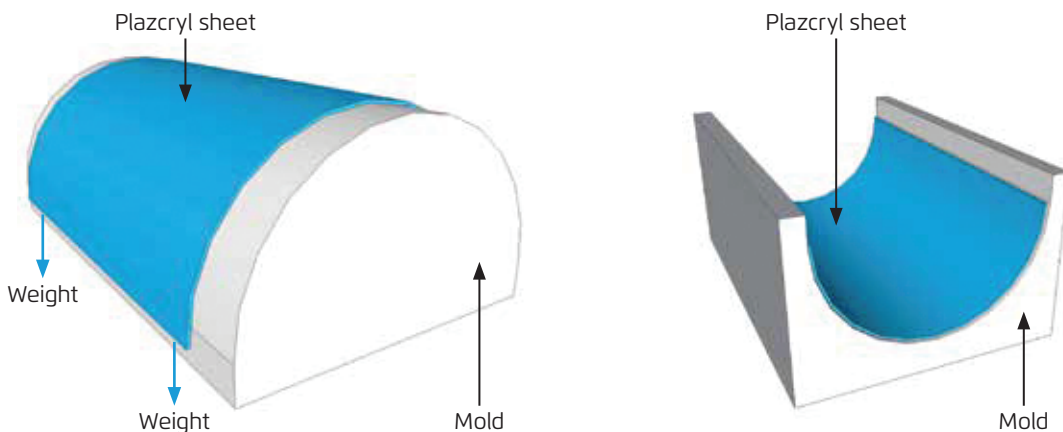

Free blown forming

This method is suitable for high optical quality and limited bubble-like part shapes. Requiring low cost equipment and short production cycles. This method is the most cost efficient for sky dome production. The free blowing equipment is composed of a plywood board attached to a compressed air source with a pressure control device. Heat Plazcryn, frame it tightly to the board and gradually increase the air pressure (or vacuum) to the desired point. Let Plazcryn cool and dismantle it after regaining its rigidity.

Please note:

1. The air pressure controls the height of the dome.
2. The shape of the dome can be altered by an imprint and by using a different frame shape.
3. The top part of the dome will be thinner than the part close to the base.
4. Since vacuum is restricted to 1 atmosphere, the use of vacuum free forming will limit the height of the dome.
5. Commonly used air pressure is 3 - 4.5 atmospheres.
6. Disperse the incoming air, using a protective plate felt or cotton wool. Cold air jet, directed onto the hot Plazcryn will cause rapid local cooling and as a result high stress and non-uniform expansion of the sheet.
7. Forming big domes is better preformed when blowing with hot air.

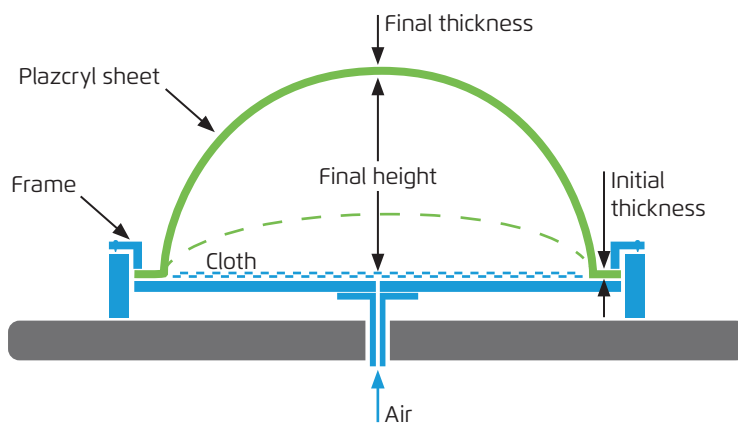

Press forming

Restricted to forming shallow parts with low quality surface (especially on the inside corners), this method is mainly used in the sign industry. The heated Plazcryn is clamped over the cavity, and then pressured into it, up to a fixed depth, by the plug. Pressing can be done by a manual drill press, air cylinder or pneumatic cylinder. The plug and cavity must match in a way that enough space will be left for the sheet.

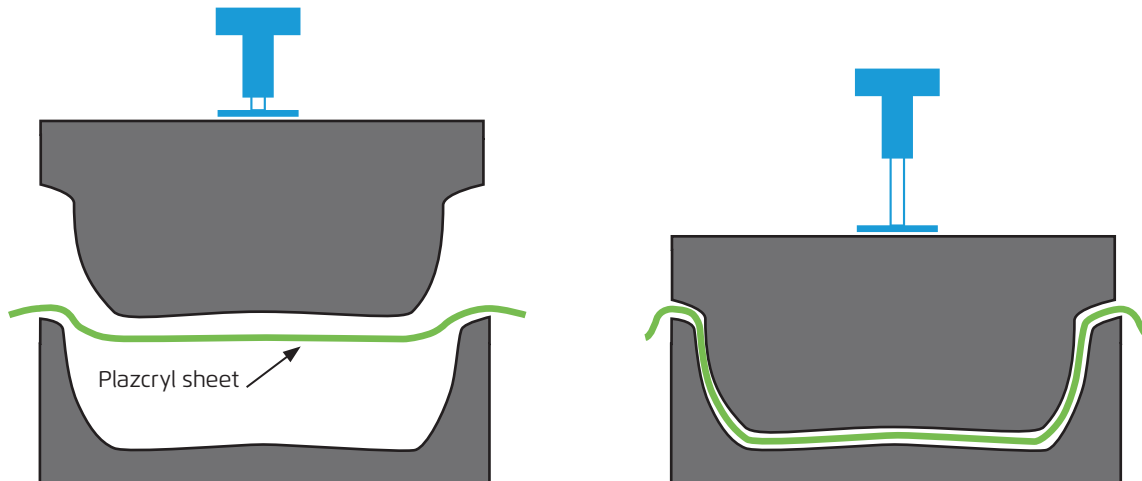

Straight vacuum (pressure) forming

This is a very simple method with fairly good results. The quality of the surface is good and the wall thickness for shallow drawn parts is quite even. Both female and male molds can be used. The heated Plazcryn is clamped over the mold. The air, trapped between Plazcryn and the mold, is then sucked through vacuum forcing the sheet to form against the mold. When using air pressure instead of vacuum it is essential to make vent holes in the mold to enable evacuation of the trapped air to form its final shape. Since vacuum is restricted to 1 bar, straight vacuum is limited to forming shallow simple parts. Using high pressure (up to 5 bar) the straight forming method can be used for more complex parts.

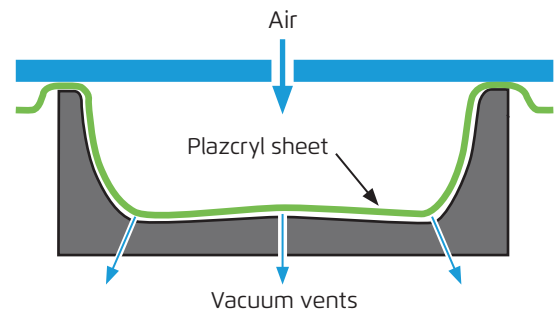

Reverse blow forming

This method is quite similar to the straight pressure forming method and the same machinery can be used. Although the only difference between the two methods is the order of events. With this method the uniformity of the wall thickness will be much better. The heated Plazcryn is clamped over a pressure box. Air pressure is used to blow Plazcryn to a bubble. The plug is then lowered into the bubble, forming the desired shape.

Plug-assist forming

This is a more demanding process. Better control of forming rate and temperature are required, and only experienced workers will be able to achieve the needed results. Plug-assist is used for forming deep drawn parts that require a better wall thickness uniformity. The heated Plazcryn is clamped over the cavity and the plug is then lowered to stretch the sheet. When the plug is in its final course, applied vacuum from the cavity or pressure from the plug forces Plazcryn against the cavity to form its final shape. For even better wall thickness uniformity, vacuum is first used to create a maximal bubble and only then the plug is lowered. When the plug is in its final course, pressure from the plug forces Plazcryn against the cavity to form its final shape. The plug will be 80% - 90% of the volume of the cavity. The shape of the plug will influence the distribution of wall thickness. The plug should be heated or at least made of low thermal conductivity material to prevent mark-off.

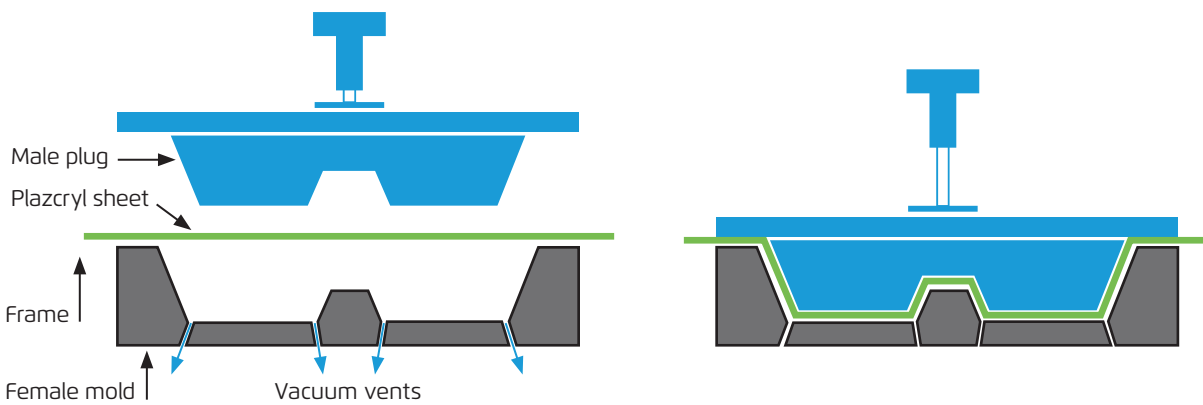

Snap-back forming

With this method complex shapes can be formed but depth is restricted. The heated Plazcryn sheet is clamped over a vacuum box. Vacuum is used to draw the Plazcryn sheet into the box forming a bubble, slightly bigger than the plug. The plug is lowered and when in place the vacuum is released causing the sheet to snap back onto the plug and form its shape. The process must be done fast enough to ensure that Plazcryn is sufficiently hot to perform the snap back. Forming complex shapes by this method requires the use of applied vacuum from the plug or pressure from the box to help Plazcryn gain its final shape from the plug.

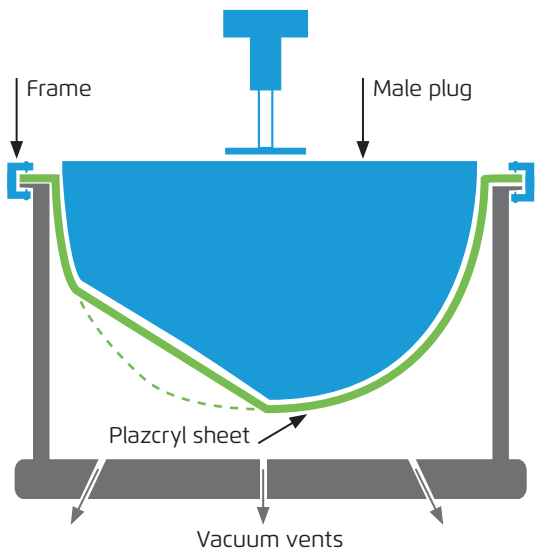

Cooling

After shaping, Plazcryn must be left on the mold, with the applied pressure to cool. Remove Plazcryn when at 60°C - 70°C. If too hot Plazcryn might not retain its shape, but if left for too long, Plazcryn might cool and shrink too much on the mold, causing excessive stress and making it hard to release it from the mold. Avoid drafts and when working in a cold environment cover Plazcryn with felt or flannel. Covering is also very important for cooling uniformly through the bulk of thick wall final parts. A heated mold helps with the gradual cooling process. Slow uniform cooling is essential to prevent stress. Cooling too fast will induce internal stresses in the part reducing its properties and making it more susceptible to ESC. A better part quality comes at the expense of a lower output rate.

Molds

Used in different forming methods and for production of different products, molds can be made of a variety of materials such as hard wood, aluminum, steel, gypsum, reinforced polyester or epoxy resins. Laminating and finishing of molds made of other materials than metal, should produce a surface which will resist wear and will prevent distortion by moisture. Aluminum made molds with temperature control will achieve best results for large quantity production. Faults in the finished mold will leave imprints on the molded part. When making a mold, the shrinking properties of Plazcryn, must be taken into account. Allow for shrinkage, to make sure that the finished part is not smaller than required (see shrinkage instructions). Mold clearance angle, must be a 3°-6° for convex parts and 0.5°- 1° for concave parts (Plazcryn tends to shrink on convex parts and away from concave parts). A heated mold will result in better part shaping and will cause a more gradual cooling, reducing induced stress. When molding Plazcryn the mold temperature range should be 60-80°C. Uniform mold heating is necessary to obtain the highest surface detail and optical quality. Keep the mold clean. Dirt and dust in the mold will imprint on the molded part. Surface embossing is sometimes used to produce patterned surfaces in Plazcryn sheets for applications such as lightning fixtures. Surface embossing is produced by pressing the hot sheet against a mold having a textured surface.

Thermoforming - Troubleshooting

Blister on the surface of the sheet

Possible cause	Possible solution
Overheating	<ul style="list-style-type: none"> • Reduce the temperature or shorten the heating time • Prevent hot spots • Increase distance between sheet and heating source

Bubbles in the sheet

Possible cause	Possible solution
Moisture in the sheet	Pre-dry the sheet before thermoforming

Uneven form

Possible cause	Possible solution
Uneven heating of the sheet	<ul style="list-style-type: none"> • Fix malfunctioning heaters • Eliminate drafts
Bad clamping	Ensure firm clamping of the sheet

Surface defects

Possible cause	Possible solution
Sheet is too hot or too cold during forming	Adjust temperatures or time
Mold too cold	Increase the mold temperature, Use controlled heat mold
Defect in the mold	Replace the mold
Dirt on the mold	Clean mold thoroughly before heating
Dirt on the sheet	Clean sheet thoroughly before heating
Scratches or indentations on the sheet before forming	Keep the sheet from scratching or indenting while handling before thermoforming. Small scratches and indentations will amplify during forming
Defects on the PE protective film	Thermoform sheets either with perfect PE film or without PE film

Imperfect form

Possible cause	Possible solution
Low pressure	Increase the pressure applied
Defect in the mold	Replace the mold
Cooling time too short	Ensure sheet is sufficiently rigid before removing from mold

Crazing

Possible cause	Possible solution
Sheet is too hot or too cold during forming	Adjust temperatures or time
Drawing is done too quickly	Reduce drawing speed
Mold too cold	Increase the mold temperature, Use controlled heat mold
Uneven heating of the sheet	<ul style="list-style-type: none"> • Fix malfunctioning heaters • Eliminate drafts
Cooling time too long	Do not allow the sheet to shrink too much on the mold
Internal stress	Anneal the part
Contact with chemicals, even in vapor form	Remove any chemicals close to the working area

Cracks or broken areas

Possible cause	Possible solution
Sheet is too hot or too cold during forming	Adjust temperatures or time
Drawing is done too quickly	Reduce drawing speed
Mold too cold	Increase the mold temperature, Use controlled heat mold
Mold angles are too sharp	Round angles and corners in the mold
Internal stress	Anneal the part

6.13 Annealing

Internal stress in Plazcryn as a consequence of machining and forming can result in crazing (very fine cracks) which will later evolve into larger cracks, especially in the presence of chemicals (for example during bonding or painting) or exposure to harsh environmental conditions (industrial and agricultural areas, motorways, repeated cleaning, etc).

Internal stress can be a result of:

1. **Machining** - All methods of machining cause local overheating, thus resulting in internal stress.
2. **Forming** - Forming Plazcryn too cold, overheating Plazcryn or cooling Plazcryn too fast or unevenly after thermoforming, will cause internal stress.

It is strongly recommended to anneal Plazcryn sheets before any bonding, painting or printing operations.

Annealing time and temperatures

Plazcryn should be annealed at 65°C - 80°C. The time needed for annealing Plazcryn will depend on the thickness of the sheet and the temperature chosen.

The general guidelines for annealing Plazcryn sheets are given in the table below:

Annealing temperature	Annealing time	Cooling time	Remarks
65°C	2 hours per each mm thickness	2 hours	Recommended for annealing of sheets following thermoforming or bonding
80°C	1 hours per each mm thickness	2 hours	Recommended for annealing of flat sheets following machining

- Insert the sheet in the annealing oven only when the oven has reached the target temperature
- Beware that the oven temperature does not drop significantly during sheet insertion.
- Sheets thicker than 8 mm should be cooled for 3 hours.
- Remove the sheet from the oven only after it has cooled below 60°C.
- It is recommended to anneal without the PE protection film.

It is important to allow the annealed parts to cool slowly in the oven, at stated above, to avoid the development of new stresses due to thermal shock during the annealing process.

6.14 Decorating

Plazcryn can be decorated by screen, digital and tampon printing and spray-painting. Inks and paints formulated for acrylic sheets must be used. Beware of using inks and paints that can chemically attack PMMA. Plazcryn sheets can also be covered with vinyl adhesive film and can be vacuum metalized.

When choosing the decorating method a few factors should be regarded:

- The quality of coloring and the number of colors needed.
- The shape of the Plazcryn sheet to be decorated.
- The required level of durability.
- Ensure that inks have appropriate UV stability.
- Will the Plazcryn be thermoformed after decoration?
- The volume of production.

Preparing Plazcryn

When decorating Plazcryn, it is important to keep its surface clean. Smallest particles, surface stains and even static charges will cause uneven spread or adherence failure of the paint. Remove the protective PE film as close as possible to the beginning of the decorating process. Keep the surface from being stained and if necessary clean Plazcryn. Use an ionizing air gun to remove dust and neutralize static charges.

Screen printing

This method is very cost efficient for high volume production and results in high quality coloring. Screen printing can be applied only on flat Plazcryn but if properly performed, thermoforming of the painted Plazcryn is possible. The screen is set to Plazcryn and then the paint is applied uniformly, passing through the open mesh on the screen transferring the pattern onto Plazcryn. When screen printing two factors should be considered.

1. The paint viscosity.
2. The mesh openings.

If the paint is too diluted or the mesh is too big the paint can sag without keeping the shape of the desired print. If the paint is too thick or the mesh is too small the paint will not flow correctly through the mesh resulting in imperfection of the print. Only the right combination, of these two factors will result in quality painting.

Screen printing - Troubleshooting

Imperfection of the print

Possible cause	Possible solution
Paint doesn't flow through mesh	<ul style="list-style-type: none"> • Dilute the paint • Use a rougher mesh
Paint sags	<ul style="list-style-type: none"> • Reduce thinner additives in the paint • Use a finer mesh
Worn screen	Replace screen
Premature paint drying	Use a slower drying paint

Crazing

Possible cause	Possible solution
Excessive stress	Anneal the sheet prior to painting
Chemical attack	Ink is not compatible with PMMA

Poor paint adhesion

Possible cause	Possible solution
Incorrect paint	Use paints recommended by the manufacturer to acrylic
Dirty surface	Use only sheets with clean surface - see "Preparing Plazcyl" section

Spray painting

The shape of Plazcyl does not limit spray painting and formed Plazcyl can be sprayed.

When spray painting few factors should be considered:

- **The paint viscosity** - together with the air pressure this factor will define the paint flow. If the flow is too fast, the paint will sag and if too slow, a dry spray will result in a matte surface.
- **The air pressure** - use the lowest air pressure possible.
- **Distance of paint gun from Plazcyl** - wrongly placing the gun will cause the same problems mentioned above.
- **Moisture** - the air delivered in the spray gun must be free of moisture.
- **Static electricity** - ionized air delivered in the spray gun will result in a more uniform paint spread.

It is advisable to use the original PE film as a protective layer. Whenever it is necessary to remove the PE film, masking tapes or water-based masking materials can be used.

Spray painting - Troubleshooting

Poor paint adhesion

Possible cause	Possible solution
Incorrect paint	Use paints recommended by the manufacturer to acrylic
Dirty surface	Use only sheets with clean surface - see "Preparing Plazcryn" section
Poor paint flow	<ul style="list-style-type: none">• Dilute the paint• Increase air pressure
Paint delivered too far from the sheet	Position the air gun closer to the sheet
Excessive moisture	Treat the delivered spray to reduce moisture

Paint sagging

Possible cause	Possible solution
Excessive paint flow	<ul style="list-style-type: none">• Decrease air pressure• Reduce thinner additives in the paint
Paint delivered too close to the sheet	Position the spray gun further from the sheet

Non uniform paint spread - Ghosting

Possible cause	Possible solution
Static electricity	Use ionized air in the spray gun

Digital printing

This technology has the ability to paint individual pieces with unique designs. The ink is ejected from a bubbler jet header, like in standard ink jet printers. The main difference is the ink applied by them. Standard ink jet printers use water based inks and they dry almost immediately on the paper media.

These inks cannot be applied on plastic surfaces. The ink media on a digital printer is solvent based and it is cured by UV lamps.

Ghosting problem when printing

When Plazcryn sheets are intended for printing applications it is recommended to order Plazcryn sheets with plain PE protective film (i.e. without any printed logos). Printed logos in the PE films can cause „ghosting“, i.e. a „watermark-like“ defect on the printed sheet. If some logo is required in the PE protective sheet, printing should be performed in the reverse side of the sheet. Electrostatic charges on the sheet surface can also cause ghosting. They should be dissipated before printing.

Adhesive film

Decorating Plazcryn, using this method, offers unlimited options. Different patterns, colors and surface finishing can be obtained. The film must be carefully chosen for the desired application. The film must be compatible with PMMA. For specific instructions, on how to apply the film to PMMA, consult the film manufacturer. Thermoforming Plazcryn with adhesive decoration film is difficult but can still be accomplished. The decorative film manufacturer should be consulted about the conditions for thermoforming.

Paint removal

Paint removal is best done according to the instruction of the paint manufacturer. Apply the recommended cleaner using a clean soft cloth and light pressure. When using cleaners, care should be taken to ensure that the ingredients are not harmful to Plazcryn (See Chemical resistance table). In any case, testing the cleaner on a hidden area before use is highly recommended. Do not scrub or use brushes. All solvents, including the ones recommended by the paint producer, can cause crazing and therefore it is necessary to anneal Plazcryn if it wasn't annealed before.



Assembling



7. Assembling Plazcryn

When choosing the assembling method for Plazcryn sheets, a few factors should be regarded:

- The strength of the joint needed.
- The transparency needed.
- The material assembled to Plazcryn.
- End use environment.
- Required durability.
- Is disassembling needed?

7.1 Screwing

When assembling Plazcryn to a different material (wood, metal, other plastics) or to rough and inaccurately fit surfaces, screwing may be the preferred solution. Like all other machining operations, cutting screw threads in Plazcryn is done in the same manner and with the same standard tools as cutting screw threads in wood. Drill a hole of the required size in Plazcryn, then use a screw-tap to cut the screw threads. It is recommended to cut threads only in one of the parts being assembled, leaving the other part with a smooth drill hole. The great advantage of assembling by screwing is that it is a reversible process, which allows for repeated assembling and disassembling.

When screwing Plazcryn sheets a few factors should be considered:

- Use sharpened screw-taps.
- Use only compatible lubricants to reduce the friction.
- When tapping a hole three times deeper than the diameter, back feed the drill, at regular intervals, to ensure removal of swarf.
- Metal fixings are recommended especially if dismantling is likely. Anneal the cut areas if glue is to be used.
- When Plazcryn will be exposed to fluctuating temperatures, allowances for thermal expansion and contraction must be provided. Drill oversize holes and slots, use compatible spacers and washers and do not overtight the screws.
- Plazcryn should not be placed in contact with incompatible materials such as soft PVC washers or silicone sealing compounds containing acetic acid or acetates. Use EPDM or neoprene washers. Use only neutral silicone.
- Special care must be taken when assembling Plazcryn sheets to other materials. Different materials have different coefficients of thermal expansion. When screwing Plazcryn to other materials allow for thermal expansion clearance.
- The space between the screw hole and the sheet's edge should be 1.5 times the hole diameter.

Screwing - Troubleshooting

Crazing while tapping

Possible cause	Possible solution
Bad drill holes	See drilling troubleshooting
Excessive stress	<ul style="list-style-type: none">• Use lubricants (compatible with PMMA)• Ensure proper swarf removal
Chemicals	Remove any chemicals close to the working area

Paint sagging

Possible cause	Possible solution
Excessive stress	<ul style="list-style-type: none">• Use a screw with smaller diameter• Use only reasonable force to fasten screws• Use rough threaded taps and screws
Contact with chemicals, even in vapor form	Remove any chemicals close to the working area
Glue presence	Anneal the part if glue is to be used

Threaded wearing

Possible cause	Possible solution
Excessive disassembling and assembling	Use metal fixing

7.2 Bonding

Plazcryl sheets can be bonded using different methods. It is essential to anneal the parts previously to bonding, in order to prevent crazing of Plazcryl. It is also recommended, after the bonded part has dried and hardened at room temperature, to perform another heat treatment for 2 to 5 hours at about 60°C to improve the quality and strength of the joint. The surfaces to be bonded must be kept clean and free from oil, dust and contaminants of any type. Cleaning the surfaces prior to bonding is recommended.

Bonding techniques are considered generally to be irreversible and are used in applications where disassembling is not required.

Safety Measures

Most types of solvents and adhesives are highly volatile, flammable and toxic.

- Always follow the adhesive manufacturer's instructions and safety instructions according with the Material Safety Data Sheet (MSDS).
- Always work in a well-ventilated area.
- Keep open flames from the area. Do not smoke in the area.
- Use respiratory protection as described in the MSDS.
- Protect skin and eyes from contact with solvents as described in the MSDS

Solvent Bonding

Solvent bonding is a popular method used to bond Plazcryn. The solvent dissolves and softens the surfaces. Upon pressure application a complete fusion can be achieved at the interface of the joint which then hardens by solvent evaporation. Possible solvents are: Dichloromethane (synonyms; DCM, Methylene chloride), Chloroform, Methyl Ethyl Ketone (synonyms; MEK), Acetone. A more tender use of pure solvents is made by mixing: Dichloromethane with 5% Acetic Acid.

WARNING!

Solvents are harmful if swallowed, inhaled or absorbed through skin. Always work according solvent's MSDS instructions.

Adhesives Types

Mixed solvent adhesives:

This type of adhesives contain small quantities of MMA and PMMA in a solvent, and therefore are more viscous than pure solvent. Similar to solvent bonding, these type of adhesives act by dissolving and softening the surfaces of the part, application of contact pressure and solvent evaporation. These adhesives can be used to bond parts which do not fit perfectly together. Commercial adhesives of this type are available. Dissolving additional PMMA chips can be done to increase adhesive viscosity.

Polymerizable adhesives:

- **Catalyst activated:** These adhesives are made from two parts, a viscous solution of acrylate monomers and a catalyst. The two parts are mixed, prior to the bonding. The catalyst polymerizes the monomers making the material in the joint chemically similar to Plazcryn. These type of adhesives render stronger joints reaching 60% to 75% of the original adjacent material strength.
- **UV activated:** Polymerization takes place under UV lamp radiation. Because acrylics are opaque to the lower UV spectrum, check that the activation wavelength of the adhesive is higher than 390 nm. Results are good for small parts. This kind of adhesives is expensive.

Characteristics of the joint	Solvents	Mixed solvent adhesives	Catalyst activated 2-component adhesives	Remarks
Strength	Fair	Good	Excellent	Fair
Weather resistance	Poor	Good	Excellent	Good
Fixing time	Rapid	Slow	Can be adjusted	Very Rapid
Transparency	Excellent	Fair	Excellent	Fair

Bonding techniques

Always work on clean parts, free of dust and oils. Try keeping the area dust free. Remember not to clean acrylic with alcohols or organic solvents. If you need to clean the best way is with warm water and mild soap and let the parts dry completely from humidity.

Assembling

Soak bonding:

A solvent bonding method. Requires smooth cuts and surfaces that fit perfectly together. The process involves soaking one of the pieces of Plazcryn that are to be joined in deep solvent. The soaked Plazcryn must be masked to ensure that only the bonded areas will be in contact with the solvent. The masking used can be any strippable coating through which the solvent cannot penetrate. Plazcryn is left in the solvent until the surface is sufficiently soft. Excessive exposure will result in a longer fixing time and may even result in a weak joint. When the surface has softened to the right point, Plazcryn is removed from the solvent and held for a few minutes to drain off the excess solvent. Then the parts should be quickly bonded and held together for 30 seconds before any pressure is applied, allowing the solvent from the soaked part to work on the un-soaked part. After these 30 seconds, the joined parts are fitted into a jig and uniform pressure should be provided. The pressure applied must be sufficient to squeeze out air bubbles and ensure good contact of the surface, but not excessive, to avoid squeezing out the material or even crazing. The joined parts must be left in the jig for 10 to 30 minutes, depending on the thickness of the joint, allowing it to harden sufficiently. Allow the joint to fix for 24 hours before further working on it.

Dip bonding:

A Solvent bonding method. This is a very delicate process requiring great skill and great care. This method also requires smooth cuts and surfaces that fit perfectly together and it is limited to the bonding of straight-line surfaces. The process involves dipping the edge of one of the pieces of Plazcryn that are to be joined in the solvent. Since only the edge is dipped, the masking process, as in soak cementing, is unnecessary. The dipping tub must be leveled. Pieces of wire or fine pins are placed in the tub to help with the support of the soaked edge. The tub is filled with solvent just above the line of the pins. Plazcryn's edge is placed on the pins to soften, held in an upright position. The help of a support is recommended to keep Plazcryn steady and in an upright position. When the edge has softened to the right point, Plazcryn is removed from the solvent, held to drain, bonded and held to fix as described above, in the dip bonding technique.

Capillary bonding:

This is the most common method of bonding. This method also requires smooth cuts and surfaces that fit perfectly together and it is limited to the bonding of straight-line surfaces. Water thin adhesives are the type of adhesives used in this method. The parts are first joined together, fixed in a jig in a way that the joint is horizontal. Then the adhesive is applied to both edges of the joint by syringe, eyedropper or a needle applicator. The adhesive will flow through the area of the joint by capillary action. The part must be left to thoroughly dry before it is removed from the jig. The time of drying depends on the thickness of the joint and the type of adhesive. It is crucial to work according to the adhesive producer's instructions.

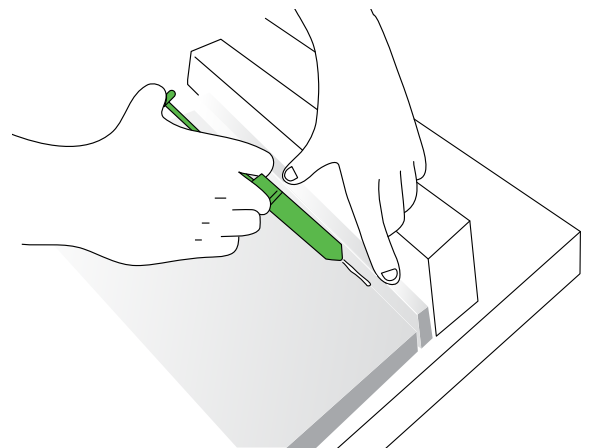

Smear bonding:

This method is used when the surfaces do not fit perfectly together. Thick polymerizable or viscous type adhesives are used in this method. The adhesive is smeared on the edge of one of the pieces of Plazcryn that are to be joined. Then, the parts are quickly bonded and fitted into a jig. The joined parts must be left in the jig for 5 to 10 minutes, depending on the thickness of the joint and the type of adhesive, allowing it to harden sufficiently. Allow the joint to fix for 24 hours before further working on it.

Bonding Plazcryn to different materials:

Plazcryn can be bonded to other materials such as metal, glass, wood, stone, etc. Cyanoacrylate and two-side adhesive tape can be used for small jobs. Care should be taken when bonding Plazcryn to other materials. Differences in thermal expansion can cause tensions that will produce failure of the bonding. In these cases an elastic adhesive or an adhesive with an intermediate coefficient of thermal expansion should be used. Consult the adhesive or tape provider for suitability and compatibility of the adhesive to PMMA and the joined material.

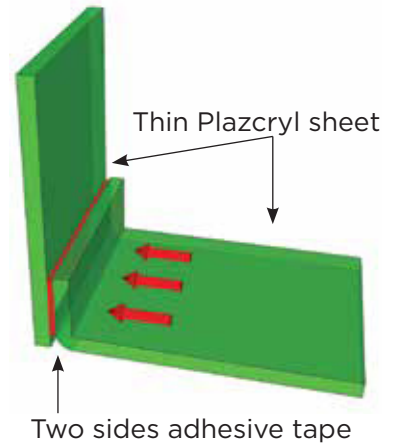

Design of Adhesive Joints:

The design of the adhesive joint has an influence on the final strength of the bond. Joints should be designed in a way that transform tensile or compressive stress to shear stress. The larger the bonding area, the stronger the bonding. Anneal parts after machining the designed joint and before bonding.

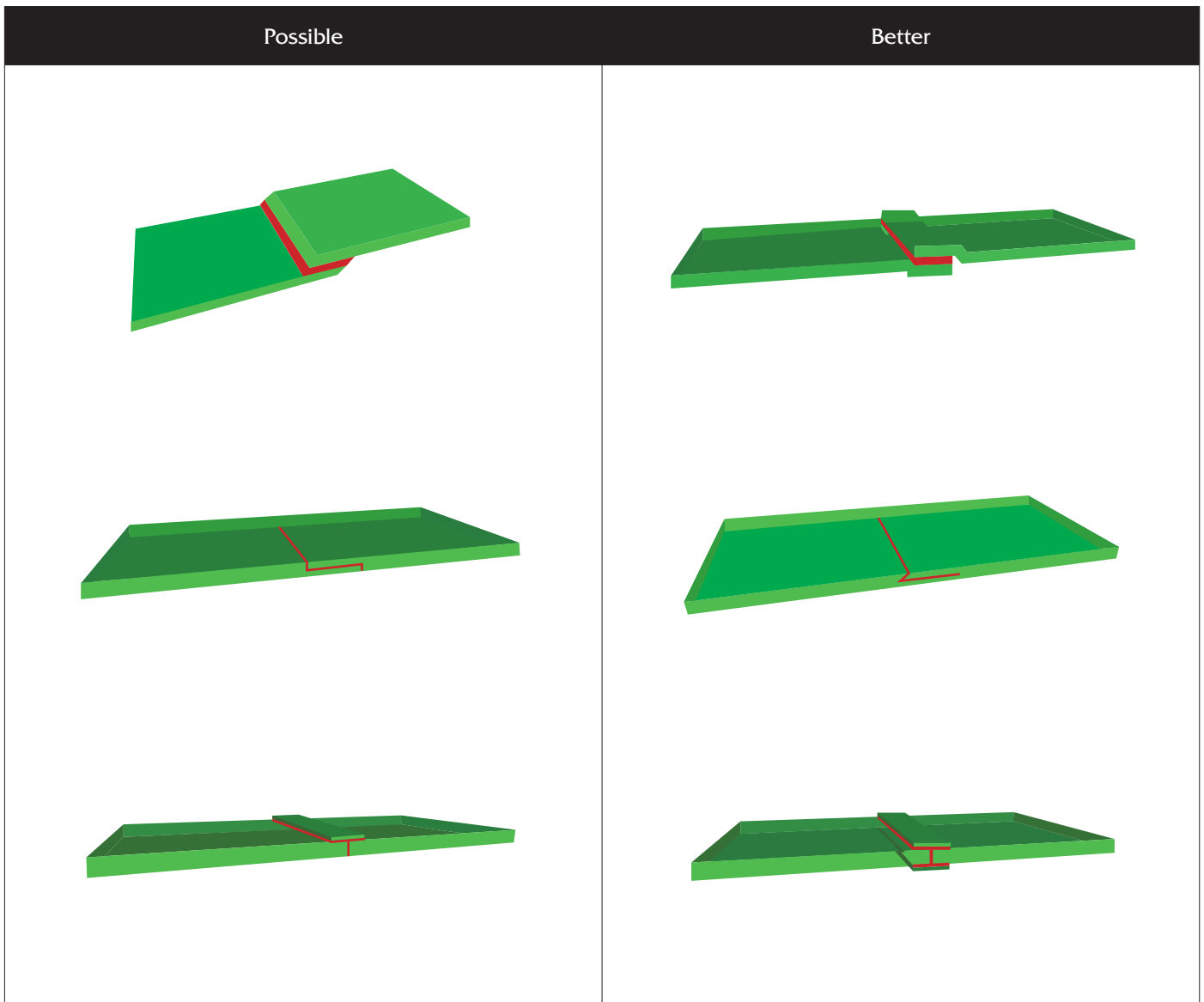

Bonding - Troubleshooting

Bubbles

Possible cause	Possible solution
Too much adhesive	Decrease the soaking time or apply less adhesive (depending on the bonding method)
Premature pressure application	Apply pressure only 30 seconds after the parts were joined
Pressure too low	Increase the pressure applied on the joint parts
Premature pressure release	Keep the joined parts pressured according to cement manufacturer instructions

Cloudiness

Possible cause	Possible solution

Crazing

Possible cause	Possible solution
Stressed edges	Anneal the parts before bonding
Excessive exposure to solvent	<ul style="list-style-type: none">• Decrease the soaking time• Use polymerizing adhesives
Curing to fast	Use slower evaporating solvents or slower curing adhesives

Poor joint strength

Possible cause	Possible solution
Parts not perfectly fit	<ul style="list-style-type: none">• Machine parts to perfect fit• Use the "Smear bonding" method
Wrong use of adhesive	Check the adhesives manufacturer instructions and act accordingly
Wrong or bad adhesive	Replace adhesive or adhesive type
Insufficient adhesive	Increase the soaking time or apply more adhesive (depending on the bonding method)
Premature pressure release	Keep the joined parts pressured according to cement manufacturer instructions
Adhesive squeezed out	Decrease the pressure applied on the joint parts.
Insufficient fixing time	Allow joint to fix for 24 hours before further working on it
Unclean surfaces	Clean surfaces before bonding
Bad designed joint	Design joint to maximize shear stress

7.3 Sealing

Joints can be sealed, either with thick polymerizable or viscous type cements, or with silicone. The type of sealant used must be compatible with Plazcryn and the joined material.

7.4 Welding

Plazcryn can be welded by different methods: hot gas, induction, ultrasonic etc. Welding is most useful when attaching Plazcryn to itself. For assembling Plazcryn to other materials, screwing or bonding may be a better option. The different welding methods generate heat energy by different ways that soften the edges and thus weld the joint. This process leaves great stress in the material, which must be relieved later by annealing. This method results in weak joints, 10% to 40% of the original strength. Welding techniques are considered generally to be irreversible and are used in applications where disassembling is not required

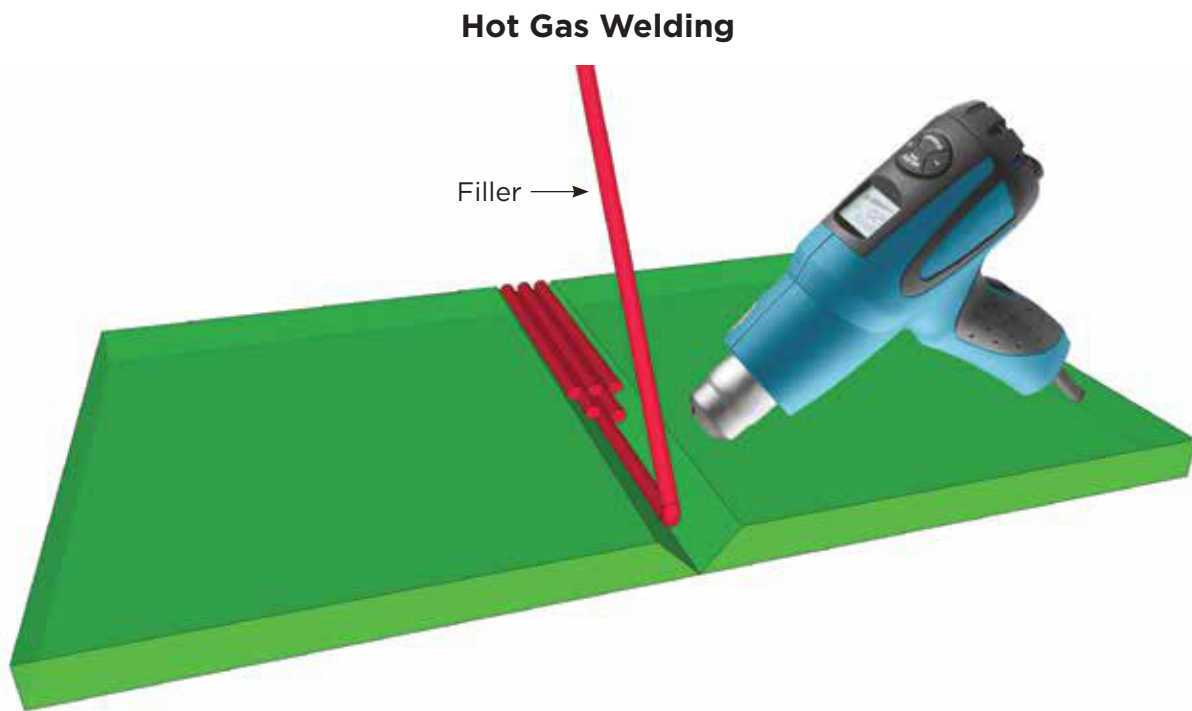

Glazing and Signage Installation



8. Glazing and Signage Installation

Light weight, high transparency and outstanding weather performance makes Plazcryn a superior glazing and signage material for both exterior as well as interior uses.

After the general desired dimensions of the sign/window are chosen, the exact dimensions of Plazcryn and frame are determined according to the following stages.

1. Determining the maximum wind load.
2. Determining thickness of the Plazcryn sheet.
3. Determining the expansion clearance.
4. Determining the groove dimensions and the exact dimensions of the Plazcryn sheet.

When Plazcryn sheets are to be mounted under extreme load or temperature conditions, accurate engineering analysis is required.

8.1 Maximum Wind Load

Determine the maximum wind load, which will be applied on the mounted sheet according to Figure 1. The maximum wind velocity in the area and the height of the mounted Plazcryn determines the wind load.

The data in Figure 1 is subject to the following remarks:

- The sheet is vertically placed - The load does not take into consideration the self-weight of the sheet and snow weight load.
- If Plazcryn is to be mounted outside of the city, the real wind load should be recalculated.

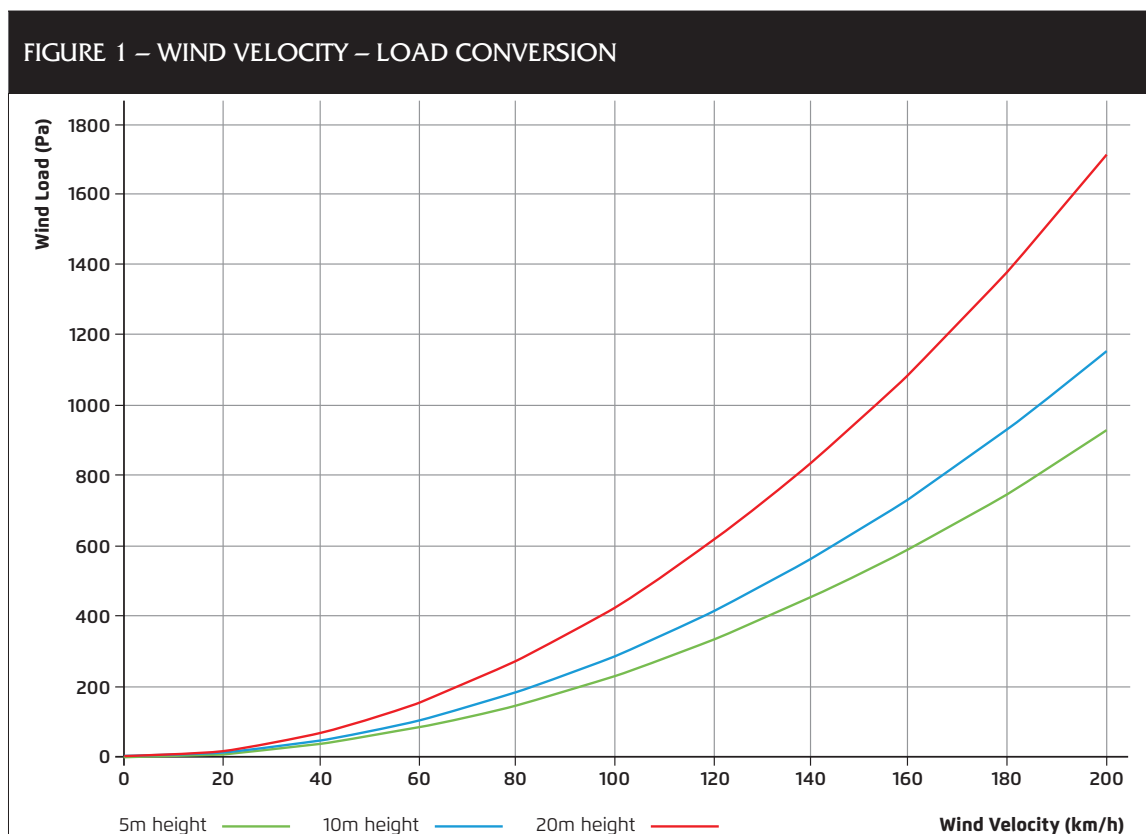

8.2 Plazcryn's Thickness

Determine the recommended thickness for the mounted sheet according to Figure 2. The wind load, as determined in the previous section, and the long dimension of the mounted sheet determine the sheet thickness.

The data in Figure 2 is subject to the following remarks:

- The sheet is supported on all four edges.
- The width is maximum 0.75 of the length - For larger widths choose the next largest thickness.
- The width is minimum 0.25 of the length - For smaller widths choose the next smallest thickness.

FIGURE 2 – PLAZCRYL PMMA SHEET THICKNESS RECOMMENDATION

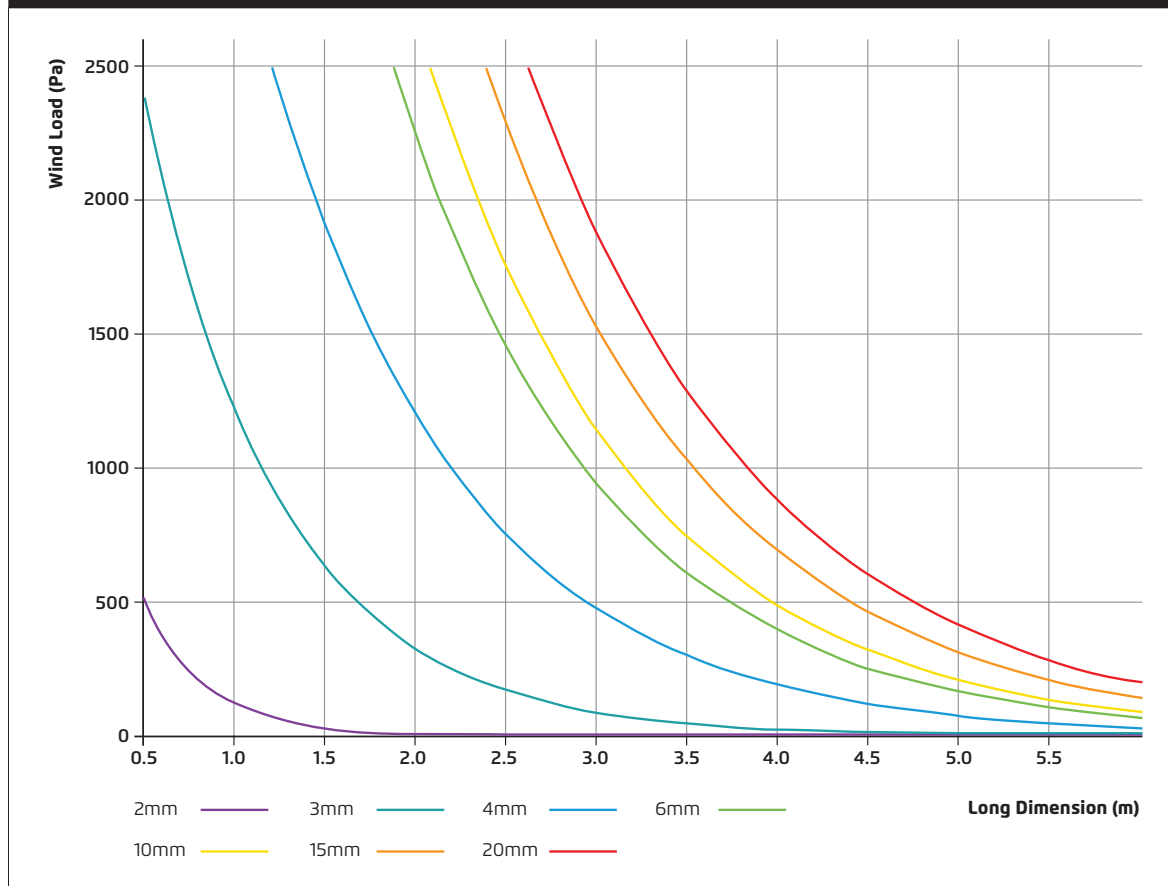

8.3 Expansion Clearance

Acrylic, like most plastics, has a coefficient of thermal expansion 4-8 times higher than all other non-plastics materials used for framing. A sufficient clearance gauge must be given allowing the sheet to expand freely. Acrylic sheets have a linear thermal expansion of 0.07 mm/m°C.

Humidity is also an expansion parameter. Plazcryl sheets expand when humidity rises. The maximum expected value of linear expansion depends on the final sheets application temperature and humidity.

The sheet dimension determines the size of the expansion clearance needed.

1. Cut Plazcryl shorter than the sash opening by the amount taken from the graph in Figure 3.
2. Cut Plazcryl into the correct size at room temperature (23°C).
3. When a sealant is used, cut Plazcryl shorter than described in paragraph 1, by twice the thickness of the sealant.
4. Use only sealing agents compatible to extruded acrylic sheets. Non-rigid PVC and PUR foam are incompatible due to migration of plasticizers. So are silicone sealing compounds containing acetic acid or acetates. Use only neutral silicones.
5. If Plazcryl is dark tinted or mounted as an illuminated sign, use the graph line named “colored”.

FIGURE 3 – EXPANSION CLEARANCE FOR PLAZCRYL PMMA SHEETS

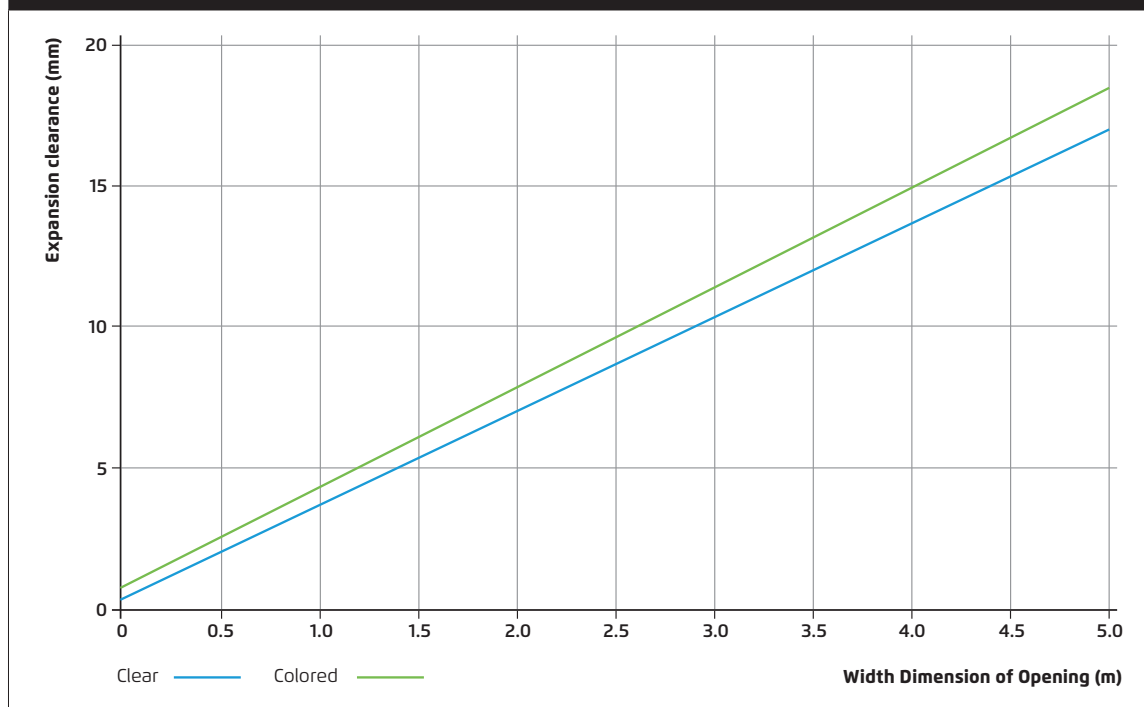

8.4 Glazing Depth

Determine the recommended glazing depth for the mounted sheet according to Figure 4. The wind load and the long dimension of the mounted sheets determine groove depth.

FIGURE 4 – GLAZING DEPTH

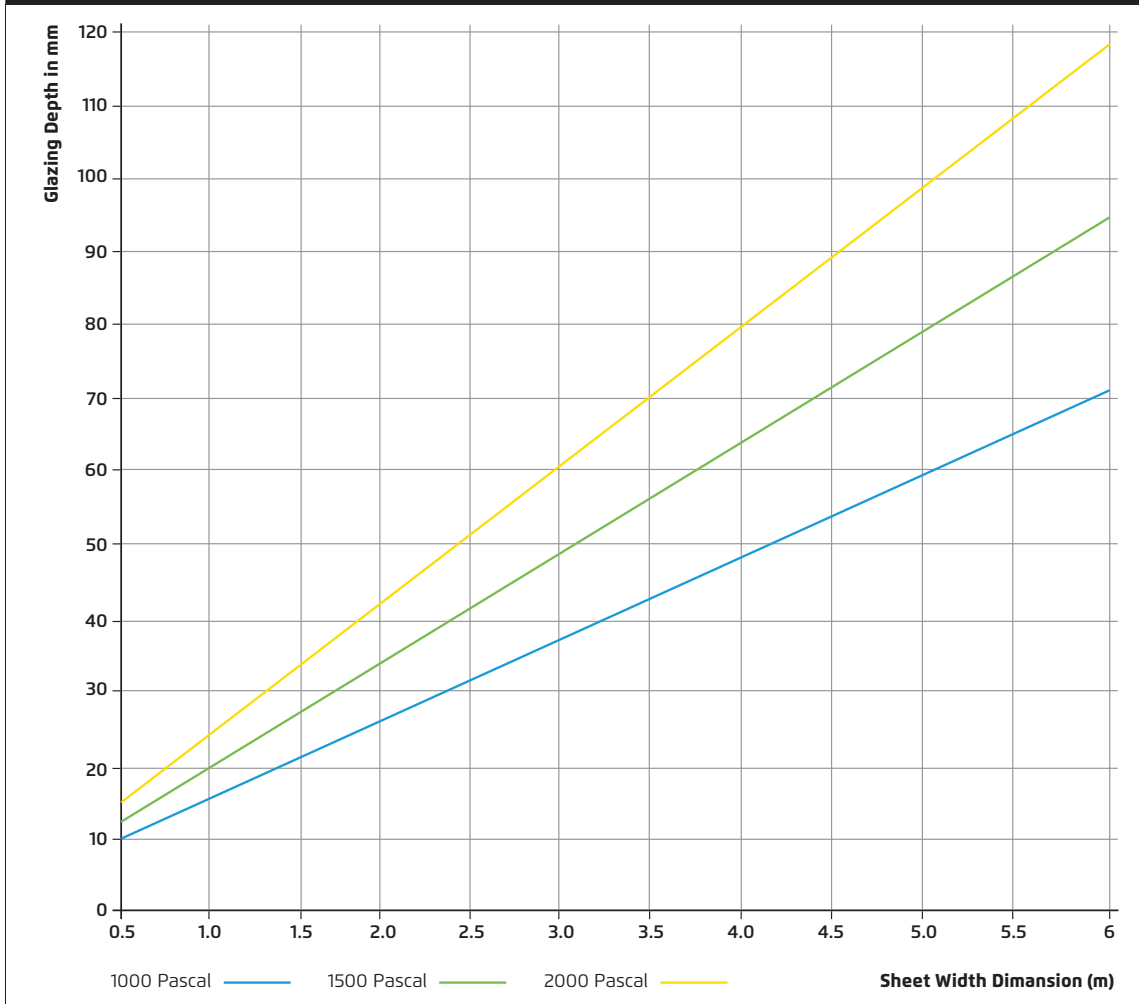

8.5 Glazing Width

The glazing width will vary according to the sheets width, the sealant width, the sealant type and the way the sheet is mounted into the glazing.

The glazing must be wide enough to allow insertion of the sheet and the sealants beads, but not too wide to prevent any possibility for vibrations of the sheet.

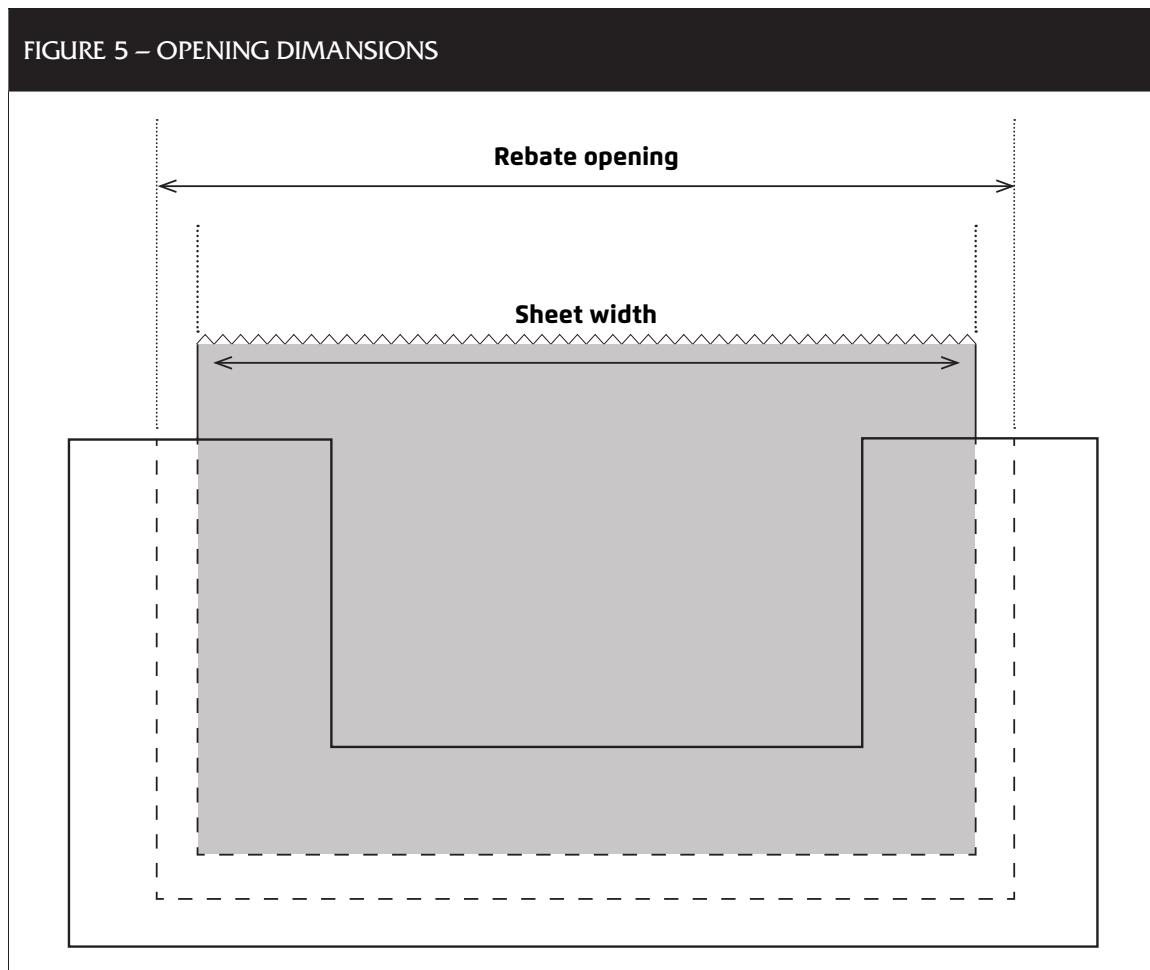

Recommended rebate depth for Plazcryl sheets:

Panel Size (mm)	Minimum Rebate (mm)	Contraction-Expansion (mm)	Total Rebate (mm)
1,000	30	+ - 5	40
1,500	33	+ - 8	50
2,000	35	+ - 10	55
3,000	40	+ - 15	70

PLASKOLITE

A GLOBAL LEADER IN THE PRODUCTION OF THERMOPLASTIC SHEET
FOUNDED IN 1950

Our Mission: to deliver superior thermoplastic sheet, coatings and polymers to the world, through long-lasting customer relationships and hands-on customer service.

MANUFACTURING LOCATIONS



These suggestions and data are based on information we believe to be reliable. They are offered in good faith, but without guarantee, as conditions and methods of use are beyond our control. We recommend that the prospective user determines the suitability of our materials and suggestions before adopting them on a commercial scale.

© 2024 **PLASKOLITE, LLC** 052024
OPTIX® is a registered trademark of PLASKOLITE LLC

PLASKOLITE

400 Nationwide Blvd, Suite 400
Columbus, OH 43215
800.848.9124 • Fax: 877.538.0754
plaskolite@plaskolite.com
www.plaskolite.com