

SEABOARD

SEABOARD® MARINE & RV MATERIALS



The VYCOM SEABOARD® family of high performance materials provides superior performance in outdoor environments where water, UV exposure, and other harsh elements are present. Unlike other wood or metal alternatives, our products will not rust, corrode, rot, delaminate, or splinter. With their superior scratch resistance, stiffness, and UV performance, SEABOARD® products are ideal for a wide range of marine, RV and outdoor living applications.

SEABOARD® PVC

SEABOARD® PVC is an expanded PVC that is ideal for wood or metal replacement

applications. The materials are lead and heavy metal free, which allows them to optimize performance while being more environmentally friendly. SEABOARD® PVC has an ideal density with a smaller cell structure enabling superior screw and staple retention. The premium UV package enhances long-term material performance.

Top Applications:

- Wood Replacement (Non-Load Bearing)
- Marine Seat Backs & Bottoms
- Cabinetry
- Shutters
- Instrumental Panels / Consoles
- Case Goods

Key Material Benefits:

- Easy to Fabricate, Paint, or Laminate with Traditional Tools
- Easy to Form, Cut & Glue
- Great Screw, Nail, & Staple Retention
- High Strength-to-Weight Ratio
- Insect Resistant
- Weatherability (UV Stabilized)
- Will Not Rot, Swell, or Peel
- 100% Recyclable

Competitive Advantages

(vs. similar materials):

- Smallest Cell Structure for Finishing
- Oversized Sheets
- Optimal Density for Superior Stiffness, Impact, & Fastening

Compliances:

- UL 94 V-0
- ASTM-E-84
- NFPA-255
- RoHS Compliant

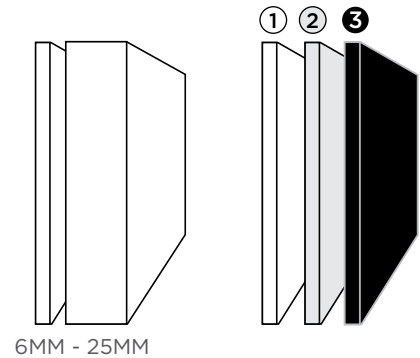

COLORS	① WHITE	② GRAY	③ BLACK
THICKNESSES	6MM - 25MM	6MM - 12MM	6MM - 25MM

Satin Smooth Finish.
Standard sheet sizes in most formulations are 4' x 8', 4' x 10'.
Custom colors and sizes available upon request.

SEABOARD® STREAMLITE® PVC

SEABOARD® StreamLite® is a light-density expanded PVC sheet product designed for economical wood or metal replacement. The materials are lead and heavy metal free, which allows them to optimize performance while being more environmentally friendly. StreamLite PVC is ideal for practical light duty applications. Its smaller cell structure enables suitable screw and staple retention. The product is UV protected for long-term material performance.

Top Applications:

- Wood Replacement (Non-Load Bearing)
- Marine Seat Backs & Bottoms
- Cabinetry
- Shutters
- Instrumental Panels / Consoles
- Case Goods

Key Material Benefits:

- Easy to Form, Cut & Glue
- Screw, Nail, & Staple Retention
- Easy to Fabricate, Paint, or Laminate with Traditional Tools
- Good Strength-to-Weight Ratio
- Insect Resistant
- Weatherability
- Will Not Rot, Swell, or Peel
- 100% Recyclable

Competitive Advantages

(vs. similar materials):

- Small Cell Structure for Finishing
- Oversized Sheets
- Good Stiffness, Impact & Fastening
- Light Density Economical Alternative

Compliances:

- UL 94 V-0
- ASTM-E-84
- NFPA-255
- RoHS Compliant

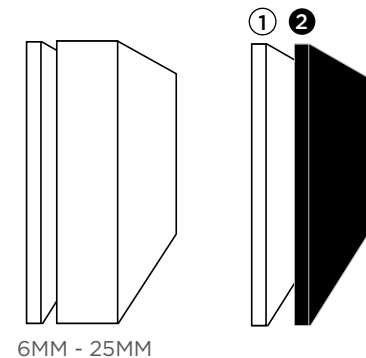

COLORS	① WHITE	② BLACK
THICKNESSES	6MM - 25MM	6MM - 25MM

Satin Smooth Finish.
Standard Sheet Sizes Available.
Custom sizes available upon request.

SEABOARD® HDPE

SEABOARD® HDPE is a UV stabilized material that has superior stiffness, scratch and impact resistance, and yet is easy to fabricate and machine for the most demanding applications. It is ideal for a variety of marine and outdoor applications.

Top Applications:

- Marine Marine & Non-Marine Outdoor Cabinetry / Furniture
- Hatches / Covers
- Rails, Trim, & Components
- Decorative Wood / Metal Replacement

Key Material Benefits:

- Excellent Scratch Resistance
- Great Impact & Stiffness
- Weatherability (UV Stabilized)
- Will Not Delaminate, Chip, Rot, or Swell
- Easy to Machine with Standard Tooling
- 100% Recyclable

Competitive Advantages

(vs. similar materials):

- Superior Scratch Resistance
- Matte Finish
- Easier to Clean
- Stiffness
- Stocked Colors, Sizes & Thicknesses
- Still FDA & USDA Compliant with UV Additive

Compliances:

- FDA*
- USDA*
- RoHS Compliant
- UL 94-HB

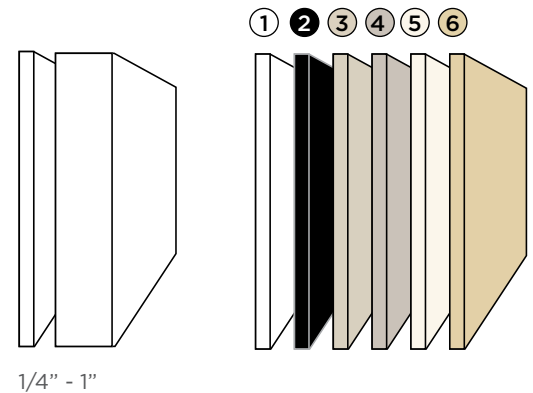

	①	②	③	④	⑤	⑥
COLORS	POLAR WHITE	BLACK	CRAFT GRAY	MERCURY GRAY	SEAFOAM	SAND SHADE
THICKNESSES	1/4" - 1"	1/4" - 1"	1/4" - 1"	1/4" - 1"	1/4" - 1"	1/4" - 1"

Standard sheet sizes in most formulations are 4' x 8', 4' x 10', 4 1/2' x 8'.
 Custom colors and sizes available upon request.
 Matte Finish
 *Black not FDA or USDA compliant.

SEABOARD® GRIP-X®

Grip-X® UV stabilized HDPE material is textured for enhanced traction and slip resistance. It is ideal for step and flooring applications.

Top Applications:

- Steps
- Flooring & Walk Ways
- Swim Platforms

Key Material Benefits:

- Non Skid Surface
- Diamond or Dot Pattern
- One Side Standard Matte Finish
- Great Impact & Stiffness
- Weatherability (UV Stabilized)
- Will Not Delaminate, Chip, Rot, or Swell
- 100% Recyclable

Competitive Advantages

(vs. similar materials):

- Superior UV Package

Compliances:

- FDA*
- USDA*
- RoHS Compliant
- UL 94-HB

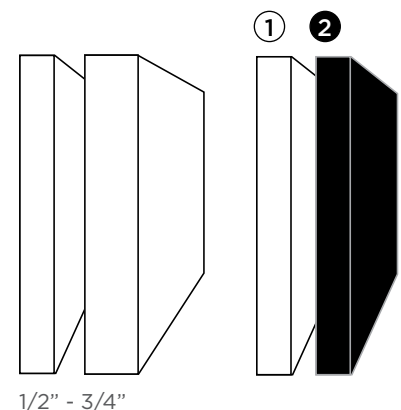

COLORS	① POLAR WHITE	② BLACK
THICKNESSES	1/2" - 3/4"	1/2" - 3/4"

Standard sheet size in most formulations is 4 1/2' x 8'.
 Custom colors and sizes available upon request.
 Non Skid (Diamond or Dot Pattern) Top Finish, Matte Bottom Finish
 *Black not FDA or USDA compliant.

SEABOARD® LITE HDPE

SEABOARD® LITE HDPE is produced utilizing co-extrusion technology that allows for solid outer surfaces with a foamed core. The core is produced with a closed cell structure that eliminates propagation of moisture within the interior and is approximately 20% less weight than solid HDPE enabling opportunities for improved performance along with cost savings.

Top Applications:

- Marine & Non-Marine Outdoor Cabinetry / Furniture
- Accessories & Components
- Hatches & Covers for Recreational Vehicles
- Decorative Wood / Metal Replacement

Key Material Benefits:

- 20% Less Weight than Solid (Foamed Core)
- Solid Skinned Surface
- Closed / Small Cell Structure - Non Absorbent
- Weatherability (UV Stabilized)
- 100% Recyclable

Standard sheet size in most formulations is 4^{1/2}' x 8'.

Custom colors and sizes available upon request.

Matte Finish

*Black not FDA or USDA compliant.

Competitive Advantages

(vs. similar materials):

- Superior Scratch Resistance
- Color Availability

Compliances:

- FDA*
- USDA*
- RoHS Compliant
- UL 94-HB

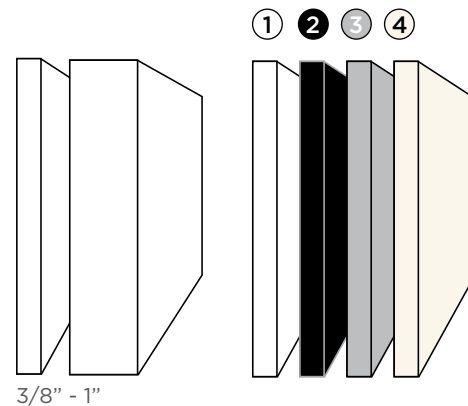

COLORS	① WHITE	② BLACK	③ GRAY	④ SEAFOAM
THICKNESSES	3/8" - 1"	3/8" - 1"	3/8" - 1"	3/8" - 1"

SEABOARD® ENDURABOND®

SEABOARD® Endurabond® expanded PVC material contains up to 100% recycled content and provides heavy duty structural and bonding properties for demanding applications, offering enhanced adhesion and optimal screw retention. Unlike wood, Endurabond is a reliable and durable material that will not rot, corrode, delaminate or splinter.

Top Applications:

- Fiberglass Bracing & Support
- Stringers & Backer Blocks
- Trailer & Industrial Flooring

Features & Benefits:

- Exceptional Structural Support
- Impact Resistant
- Excellent Surface Adhesion Characteristics
- 100% Recyclable

Standard sheet size is 4' x 8'.

Custom colors, sizes and thicknesses available upon request.

Competitive Advantages

(vs. similar materials):

- Increased Screw Retention & Fastening Properties
- Cleaner Fabrication Versus Plywood & Other Traditional Materials
- Minimizes Tool Wear Improving Maintenance Cycles

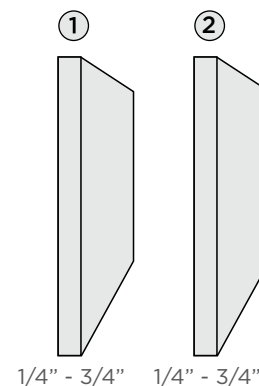

COLORS	① GRAY	② GRAY
THICKNESSES	1/4" - 3/4"	1/4" - 3/4"
FINISH	COARSE	SMOOTH



VYCOM[®]

OLEFIN & PVC SHEET

These suggestions and data are based on information we believe to be reliable. They are offered in good faith, but without guarantee, as conditions and methods of use are beyond our control. We recommend that the prospective user determines the suitability of our materials and suggestions before adopting them on a commercial scale.

© 2024 **PLASKOLITE, LLC** 072024
VYCOM[®] and SEABOARD[®] are registered trademarks of PLASKOLITE LLC

PLASKOLITE

400 W. Nationwide Blvd, Suite 400
Columbus, OH 43215
800.848.9124 • Fax: 877.538.0754
plaskolist@plaskolite.com
www.plaskolite.com